

MIRO

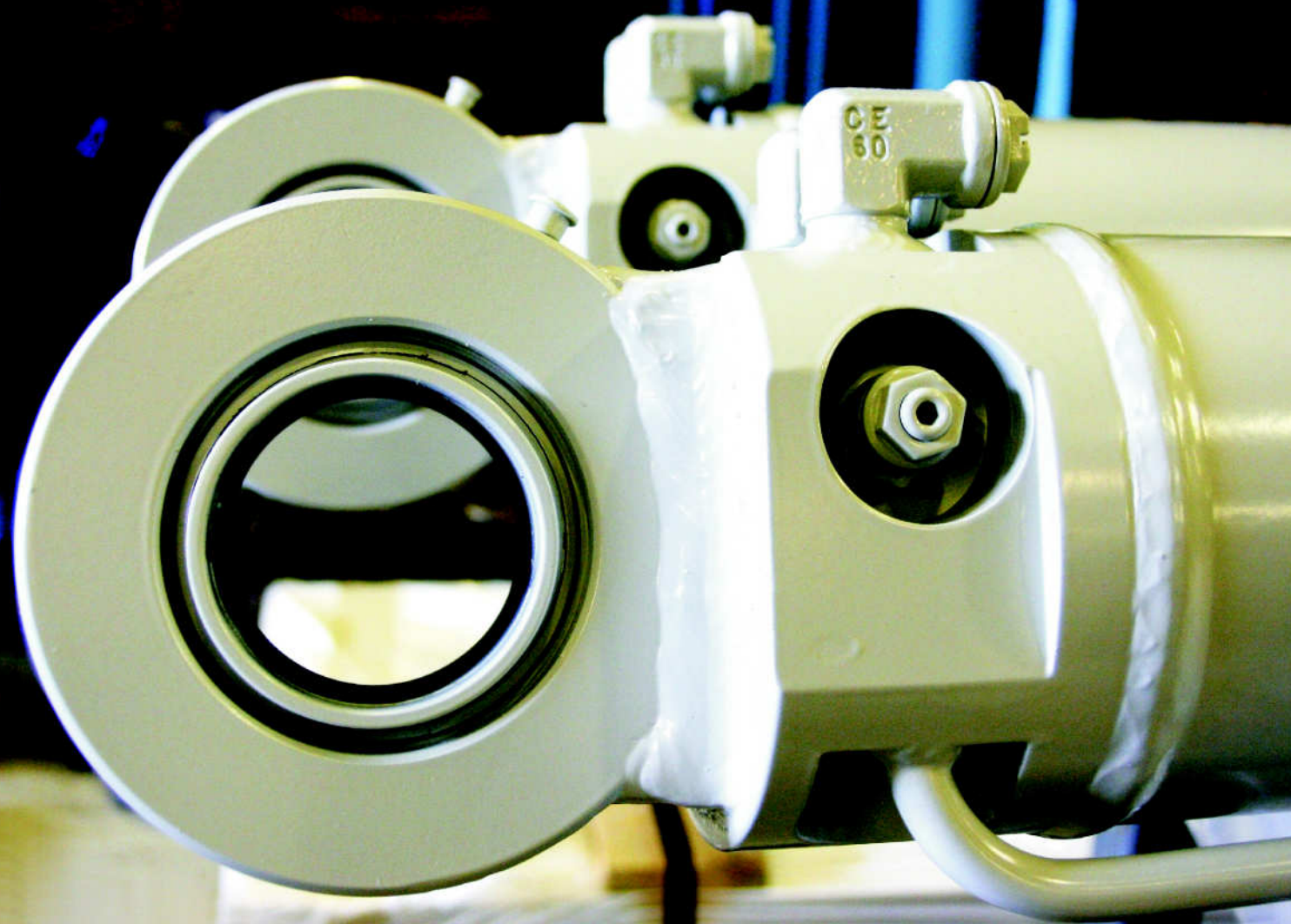

PIKAPAJA OY
MIROTIE 3
86800 PYHÄSALMI
TEL. +358-8-7691100
FAX. +358-8-782127
WWW.PIKAPAJA.FI
SALES@MIRO.EU



ISO 9001
ISO 14001

INHALTSVERZEICHNIS

C-10/1 MASSTABELLE	4
C-10/1 MASSZEICHNUNG	5
25-10/1 MASSTABELLE	7
25-10/1 MASSZEICHNUNG	8
25-10/1 LAGERBUCHSE MIT GEWINDE	9
25-20/2 MASSTABELLE	10
25-20/2 MASSZEICHNUNG	11
25-20/2 LAGERBUCHSE MIT GEWINDE	12
25-30/3 MASSTABELLE	13
25-30/3 MASSZEICHNUNG	14
25-30/3 LAGERBUCHSE MIT GEWINDE	15
25-40/4 MASSTABELLE	16
25-40/4 MASSZEICHNUNG	17
25-40/4 LAGERBUCHSE MIT GEWINDE	18
B-10/1 MASSTABELLE	20
B-10/1 MASSZEICHNUNG	21
B-10/1 LAGERBUCHSE MIT GEWINDE	22
B-20/2 MASSTABELLE	23
B-20/2 MASSZEICHNUNG	24
B-20/2 LAGERBUCHSE MIT GEWINDE	25
B-30/3 MASSTABELLE	26
B-30/3 MASSZEICHNUNG	27
B-30/3 LAGERBUCHSE MIT GEWINDE	28
B-40/4 MASSTABELLE	29
B-40/4 MASSZEICHNUNG	30
B-40/4 LAGERBUCHSE MIT GEWINDE	31

TYP C

C-10/11

*OHNE SCHMIRNIPPEL.

Ø	A	B	C ₁	C ₂	C ₃	C ₄	D	E	F	G	H	I	J	K	L	M	N	O	P	R	Ø
32*	149	131	16	18	20	-	M 12	15	15	40	34	R 1/4	34	40	33	10	9	12	15	19	32*
40	194	163	20	22	25	-	M 14	20	12	50	41	R 3/8	47	47	43	16	14	20	25	31	40
50	198	169	25	28	30	36	M 20x1.5	25	13	60	46	R 3/8	49	55	42	16	14	20	25	31	50
60	217	183	30	32	36	40	M 24x2	30	14	70	57	R 1/2	57	55	48	20	18	25	28	35	60
63	215	183	32	36	40	45	M 24x2	30	16	73	59	R 1/2	56	55	48	20	18	25	28	35	63
70	235	200	36	40	45	50	M 30x2	35	16	80	62	R 1/2	61	62	51	22	20	30	31	37	70
80	258	217	40	45	50	56	M 36x3	40	17	90	67	R 1/2	69	64	58	25	22	35	35	45	80
90	268	219	45	50	56	63	M 39x3	42	17	105	72	R 1/2	77	62	66	28	25	40	40	50	90
100	291	236	50	56	60	70	M 42x3	45	17	115	77	R 1/2	84	67	72	32	28	45	45	56	100
110	293	238	56	63	70	80	M 42x3	45	17	125	85	R 1/2	86	67	72	32	28	45	45	56	110
125	313	248	63	70	80	90	M 56x3	55	17	140	92	R 1/2	99	70	82	35	35	50	51	62	125
140	344	275	70	80	90	100	M 64x3	64	20	160	102	R 1/2	108	74	89	44	40	60	62	69	140

BESTELL BEISSPIEL

C - 10 - 60 / 40 x 500 - A - SS - 12 - 3

DRUCKKLASSE

BEFESTIGUNGSTYP

INNENDURCHMESSER DES ZYLINDERS Ø

DURCHMESSER DER STANGE Ø C

SCHUBLÄNGE

SCHLAUCHANSCHLUSSTELLE AUF DER VONDERSEITE

SCHLAUCHANSCHLUSSTELLE AUF DER HINTERSEITE

SCHMIERNIPPELSTELLE AUF DER VONDERSEITE

SCHMIERNIPPELSTELLE AUF DER HINTERSEITE

TYP C - 10

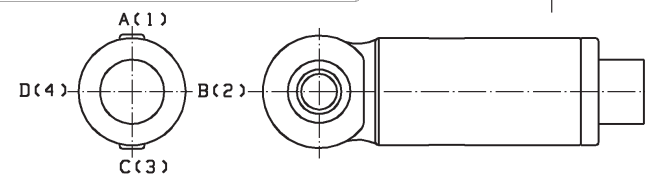
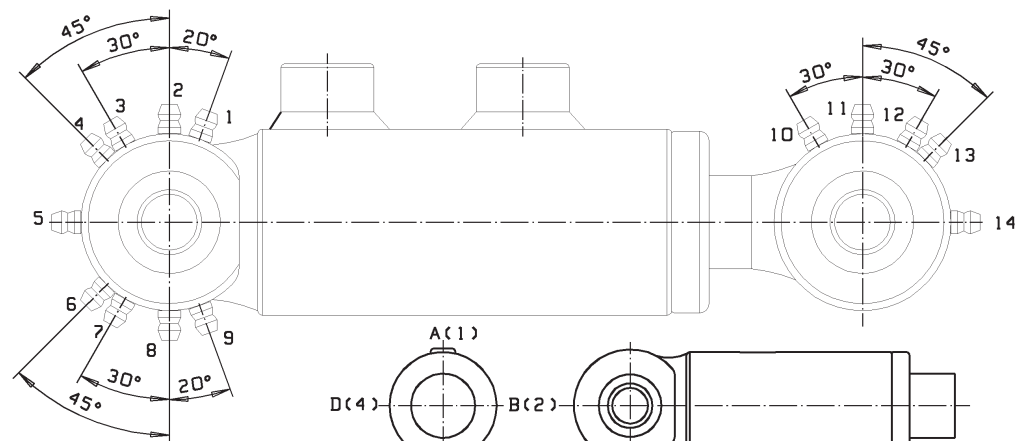
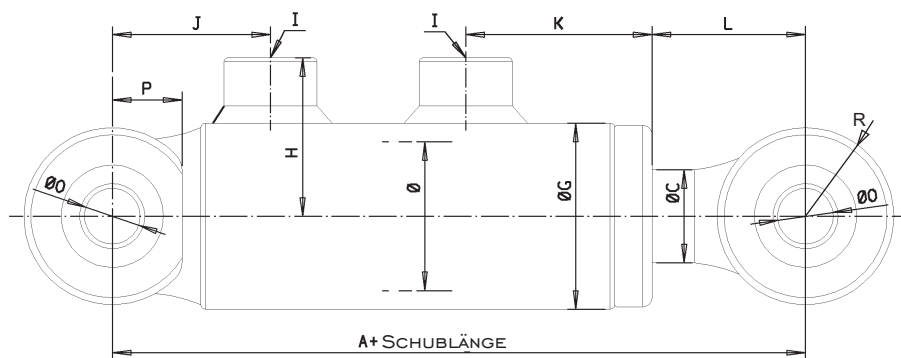

ÖLANSCHLUSS-U., VORDERSEITE.

TYP C - 11

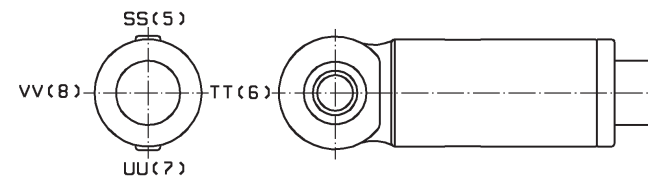
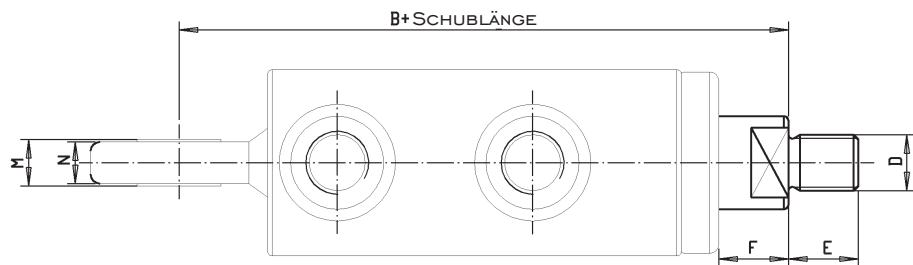

ÖLANSCHLUSS-U., HINTERSEITE.

TYP 25

25-10/11

*OHNE SCHMIRNIPPEL.

Ø	A	B	C1	C2	C3	C4	D1	D2	D3	E1	E2	E3	F	G	H	I	J	K	L	M	O	P	R	S	U	Z	Ø
25*	158	139	12	14	16	-	M 12	-	M 12x1.25	20	-	16	10	48	35	R 1/4	36	32	45	38	12	15	19	29	12	19	25*
32	186	160	16	18	20	22	M 16x1.5	-	-	16	16	22	12	52	40	R 3/8	42	39	55	42	20	22	28	38	20	28	32
40	220	191	20	22	25	28	M 16x1.5	-	M 20x1.5	20	16	28	12	62	50	R 3/8	51	41	58	47	25	25	31	41	25	31	40
50	238	204	25	28	30	36	M 22x1.5	-	-	22	22	-	17	75	60	R 1/2	59	46	65	60	30	30	37	51	28	37	50
60	249	215	30	32	36	40	M 22x1.5	-	-	23	23	-	16	85	70	R 1/2	59	47	66	65	30	30	37	50	28	37	60
63	267	225	32	36	40	45	M 28x1.5	-	-	29	29	-	17	90	73	R 1/2	69	47	66	67	35	40	47	59	30	47	63
70	280	233	36	40	45	50	M 35x1.5	-	M 33x2	35	35	45	17	95	80	R 1/2	75	51	70	70	40	44	52	64	32	52	70
80	292	241	40	45	50	56	M 36x2	-	-	40	-	-	17	106	90	R 1/2	77	50	70	75	45	47	55	68	40	55	80
90	306	248	45	56	60	63	M 42x3	M 45x1.5	M 42x2	45	45	55	17	118	100	R 1/2	83	53	73	81	50	51	60	75	45	60	90
100	352	281	50	60	63	70	M 42x3	M 58x1.5	-	45	58	-	17	132	115	R 3/4	101	61	84	91	60	63	73	88	50	73	100
110	356	286	56	63	70	80	M 42x3	M 58x1.5	-	45	58	-	17	150	125	R 3/4	101	61	84	100	60	63	73	87	50	73	110
125	406	307	60	70	80	90	M 56x3	M 65x1.5	M 56x2	55	65	75	17	160	140	R 1	120	70	98	107	70	76	84	99	60	84	125
140	463	369	80	90	100	-	M 64x3	M 80x2	-	64	80	85	20	180	160	R 1	130	90	118	117	80	84	94	114	65	94	140
160	540	420	90	100	110	-	M 72x3	M 100x2	-	70	100	90	20	210	180	R 1 1/4	160	95	128	135	90	100	100	140	70	120	160

LAGERBUCHSE MIT GEWINDE SIND AUF DER NÄCHSTEN SEITE.

() = ZUSATZTEILE, WENN NÖTIG.

BESTELL BEISSPIEL

25 - 10 - 100 / 60 x 1000 - A - SS - 11 - 2 - (2 - 6)

DRUCKKLASSE

BEFESTIGUNGSTYP

INNENDURCHMESSER DES ZYLINDERS Ø

DURCHMESSER DER STANGE Ø C

SCHUBLÄNGE

SCHLAUCHANSCHLUSSTELLE AUF DER VONDERSEITE

SCHLAUCHANSCHLUSSTELLE AUF DER HINTERSEITE

SCHMIERNIPPELSTELLE AUF DER VONDERSEITE

SCHMIERNIPPELSTELLE AUF DER HINTERSEITE

ENTLUEFTUNGSSCHRAUBENSTELLE AUF DER VONDERSEITE

ENTLUEFTUNGSSCHRAUBENSTELLE AUF DER HINTERSEITE

TYP 25 - 10

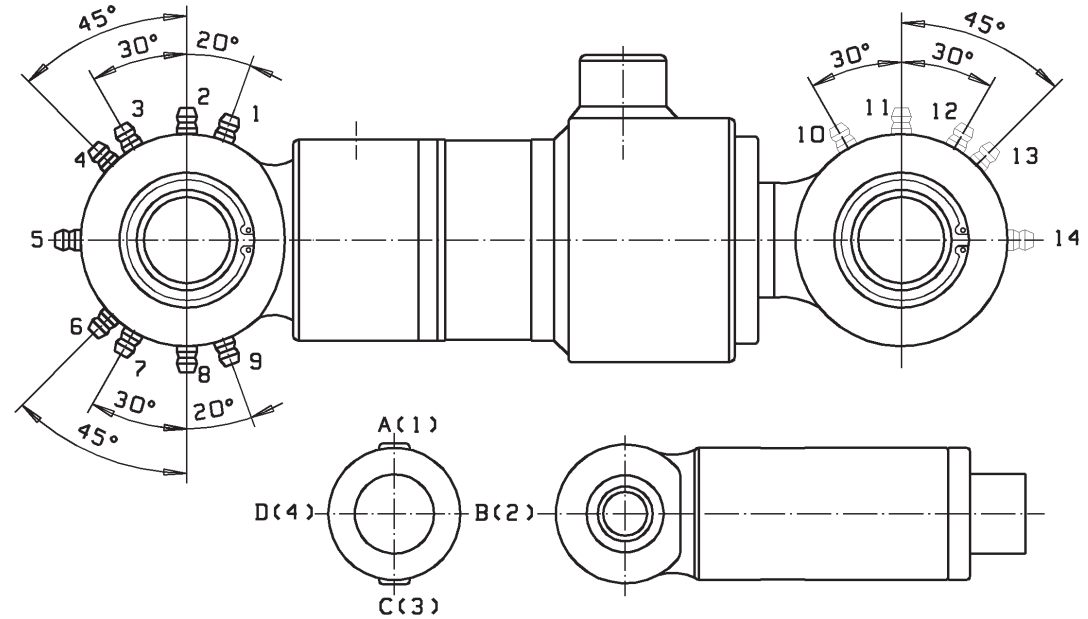
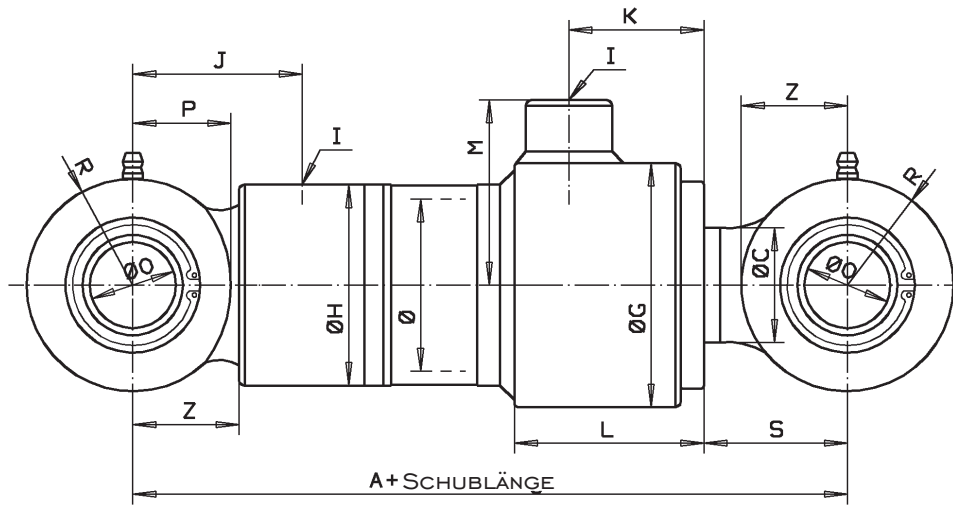

ÖLANSCHLUSS-U., VORDERSEITE.

TYP 25 - 11

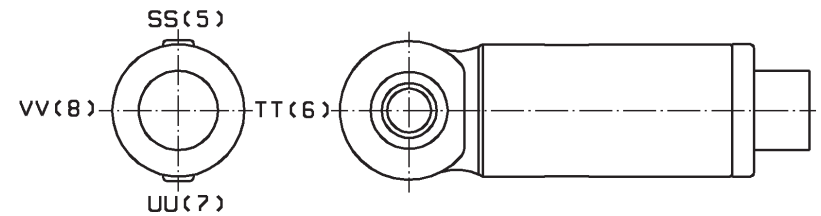
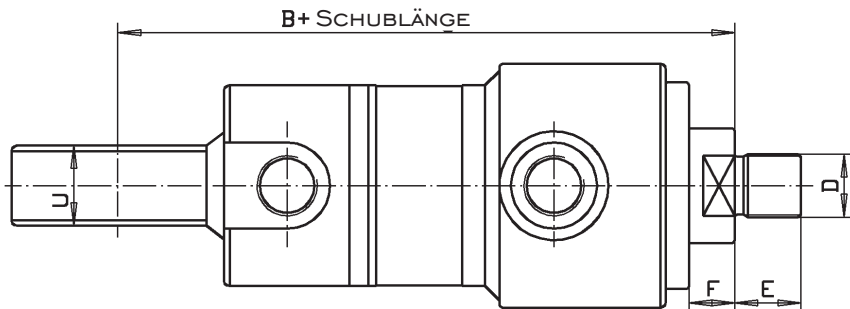

ÖLANSCHLUSS-U., HINTERSEITE.

TYP 25 - I I

LAGERBUCHSE MIT GEWINDE

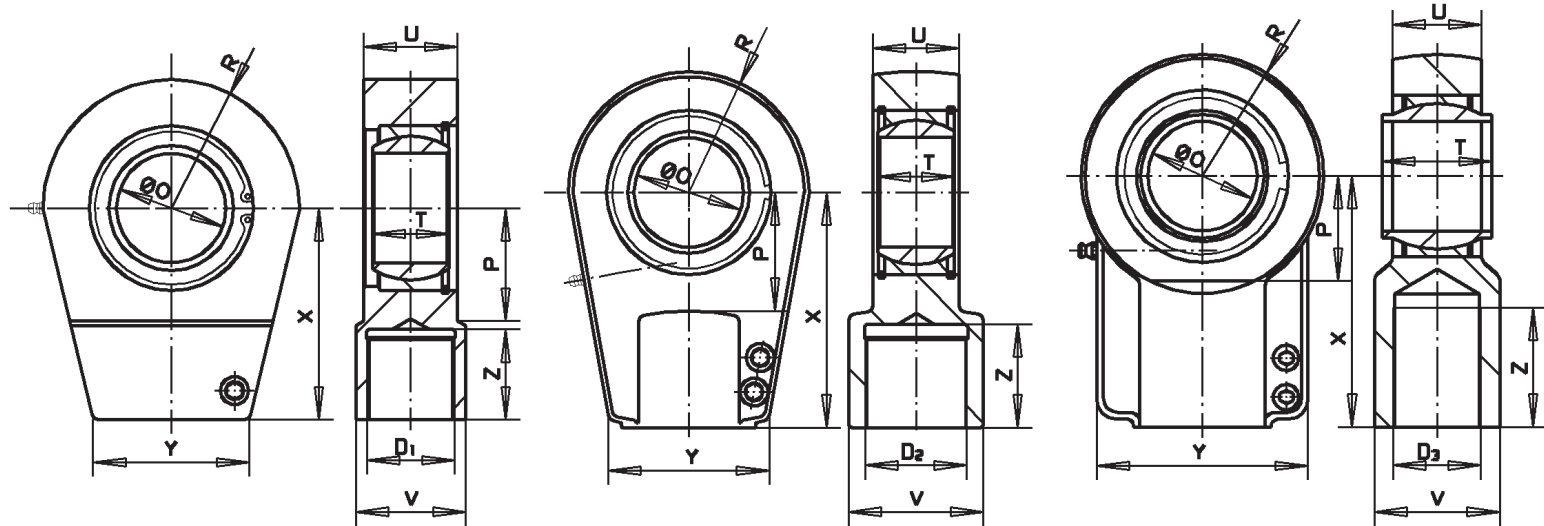

MIRO - XL

GIHR - K DO

GIHN - K LO

TYP	Ø O	D	X	Y	Z	V	P	T	U	R	SYL Ø
GIHN-K	12	M 12x1,25	38	32	17	16,5	14	12	10,6	16	25
GIHN-K	20	M 16x1,5	52	47	23	25	22	20	17	23,5	32
GIHR-K	20	M 16x1,5	50	41	17	25	25	16	19	28	32
GIHN-K	25	M 20x1,5	65	54	29	30	27	25	21	29	40
GIHR-K	25	M 16x1,5	50	41	17	25	25	20	23	28	40
GIHR-K	30	M 22x1,5	60	46	23	32	30	22	28	32	50
GIHR-K	30	M 22x1,5	60	46	23	32	30	22	28	32	60
GIHR-K	35	M 28x1,5	70	58	29	40	38	25	30	39	63
GIHN-K	40	M 33x2	97	80	46	47	41	40	32	44,5	70
GIHR-K	40	M 35x1,5	85	66	36	49	45	28	35	47	70
MIRO-XL	45	M 36x2	95	74	42	50	45	32	40	53	80
GIHN-K	50	M 42x2	120	96	57	58	50	50	40	54	90
GIHR-K	50	M 45x1,5	105	88	46	61	55	35	40	58	90
MIRO-XL	60	M 42x3	115	85	47	60	57	44	50	68	100
GIHR-K	60	M 58x1,5	130	90	59	75	65	44	50	65	100
MIRO-XL	60	M 42x3	115	85	47	60	57	44	50	68	110
GIHR-K	60	M 58x1,5	130	90	59	75	65	44	50	65	110
MIRO-XL	70	M 56x3	137	105	57	70	72	49	60	80	125
GIHN-K	70	M 56x2	160	135	76	80	70	70	57	77,5	125
GIHR-K	70	M 65x1,5	150	100	66	86	75	49	55	77	125
MIRO-XL	80	M 64x3	155	112	66	80	80	55	65	90	140
GIHN-K	80	M 64x3	180	148	86	90	78	80	66	84	140
GIHR-K	80	M 80x2	170	125	81	102	80	55	60	88	140
MIRO-XL	90	M 72x3	174	130	72	90	90	60	70	100	160
GIHN-K	90	M 72x3	195	160	91	100	85	90	72	92,5	160
GIHR-K	90	M 100x2	210	146	101	124	90	60	65	103	160

25-20/21

*OHNE SCHMIRNIPPEL.

Ø	A	B	C1	C2	C3	C4	D1	D2	D3	E1	E2	E6	F	G	H	I	J	K	L	M	O	R	S	U	Z	AA	BB	CC	DD	EE	FF	Ø
25*	37	18	12	14	16	-	M 12	-	M 12x1.25	20	-	16	10	48	35	R 1/4	17	25	102	35	12	19	29	12	19	70	22	3	50	75	9	25*
32	48	22	16	18	20	22	M 16x1.5	-	-	16	16	22	12	70	40	R 3/8	14	30	110	35	20	28	38	20	28	70	27	3	60	80	9	32
40	51	22	20	22	25	28	M 16x1.5	-	M 20x1.5	20	16	28	12	70	50	R 3/8	20	33	138	38	25	31	41	25	31	90	15	2	70	90	11	40
50	61	27	25	28	30	36	M 22x1.5	-	-	22	22	-	17	75	60	R 1/2	22	36	140	60	30	37	51	28	37	110	17	2	85	110	13	50
60	61	27	30	32	36	40	M 22x1.5	-	-	23	23	-	16	90	70	R 1/2	22	36	151	65	30	37	50	28	37	120	17	3	90	120	17	60
63	70	28	32	36	40	45	M 28x1.5	-	-	29	29	-	17	90	73	R 1/2	22	36	150	67	35	47	59	30	47	130	17	3	100	130	17	63
70	76	29	36	40	45	50	M 35x1.5	-	M 33x2	35	35	45	17	100	80	R 1/2	23	39	152	70	40	52	64	32	52	140	19	4	110	140	17	70
80	81	30	40	45	50	56	M 36x2	-	-	40	-	-	17	115	90	R 1/2	22	38	156	75	45	55	68	40	55	150	20	5	120	160	21	80
90	88	30	45	56	60	63	M 42x3	M 45x1.5	M 42x2	45	45	55	17	125	100	R 1/2	23	40	158	81	50	60	75	45	60	170	22	5	130	180	21	90
100	101	30	50	60	63	70	M 42x3	M 58x1.5	-	45	58	-	17	132	115	R 3/4	28	48	178	91	60	73	88	50	73	180	24	5	145	190	21	100
110	100	30	56	63	70	80	M 42x3	M 58x1.5	-	45	58	-	17	150	125	R 3/4	28	48	183	100	60	73	87	50	73	190	24	5	150	200	25	110
125	114	32	60	70	80	90	M 56x3	M 65x1.5	M 56x2	55	65	75	17	170	140	R 1	36	55	208	107	70	84	99	60	84	210	28	5	180	230	25	125
140	134	40	80	90	100	-	M 64x3	M 80x2	-	64	80	85	20	190	160	R 1	36	70	235	117	80	94	114	65	94	240	30	5	200	250	31	140
160	160	40	90	100	110	-	M 72x3	M 100x2	-	70	100	90	20	222	180	R 1¼	40	75	260	135	90	100	140	70	120	260	33	5	220	280	31	160

LAGERBUCHSE MIT GEWINDE SIND AUF DER NÄCHSTEN SEITE.

() = ZUSATZTEILE, WENN NÖTIG.

BESTELL BEISSPIEL

25 - 20 - 100 / 60 x 1000 - A - SS - 11 - (2 - 6)

DRUCKKLASSE

BEFESTIGUNGSTYP

INNENDURCHMESSER DES ZYLINDERS Ø

DURCHMESSER DER STANGE Ø C

SCHUBLÄNGE

SCHLAUCHANSCHLUSSTELLE AUF DER VONDERSEITE

SCHLAUCHANSCHLUSSTELLE AUF DER HINTERSEITE

SCHMIERNIPPELSTELLE AUF DER VONDERSEITE

ENTLUEFTUNGSSCHRAUBENSTELLE AUF DER VONDERSEITE

ENTLUEFTUNGSSCHRAUBENSTELLE AUF DER HINTERSEITE

TYP 25 - 20

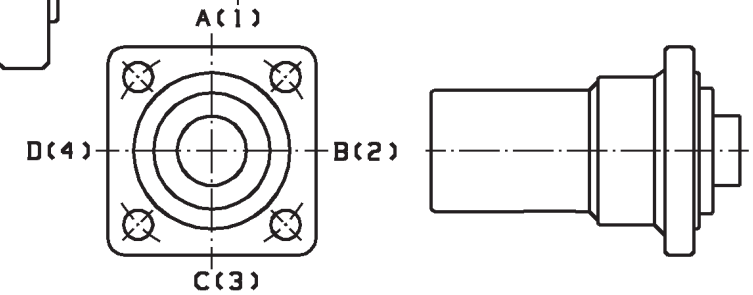
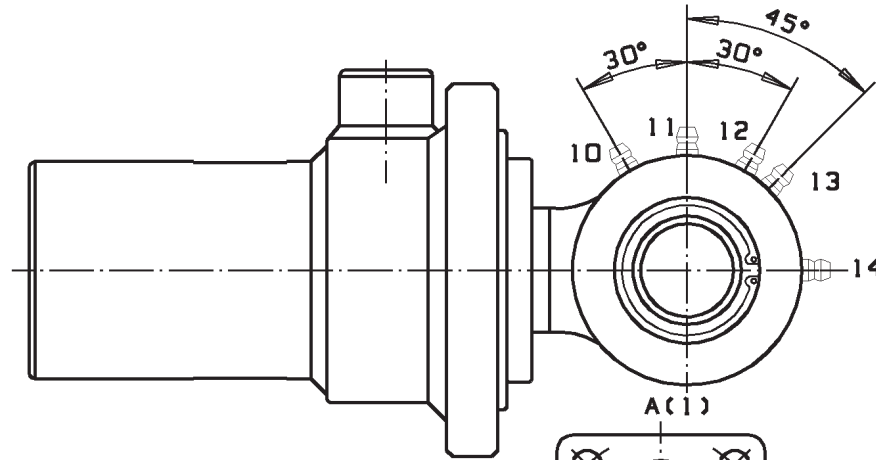
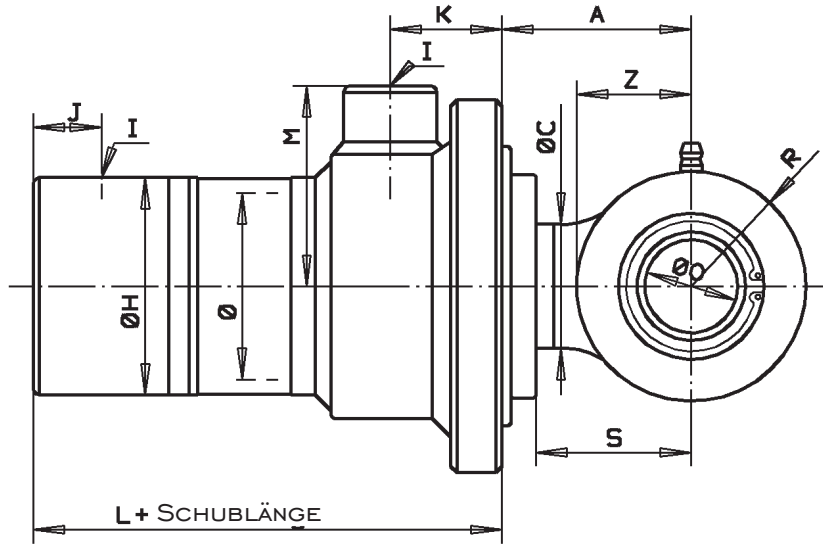

ÖLANSCHLUSS-U., VORDERSEITE.

TYP 25 - 21

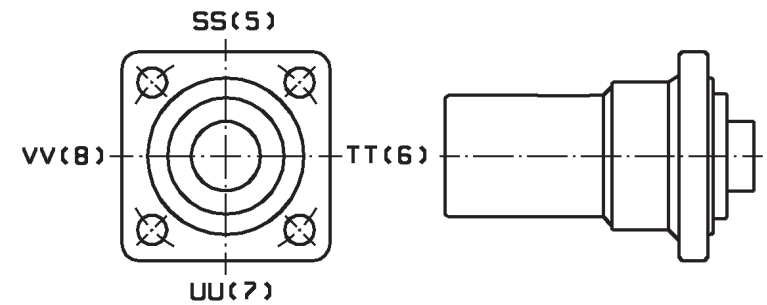
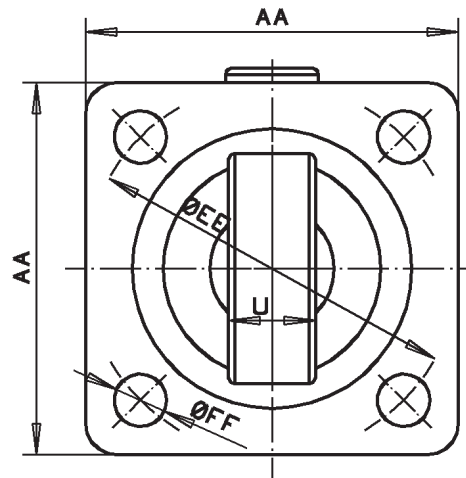
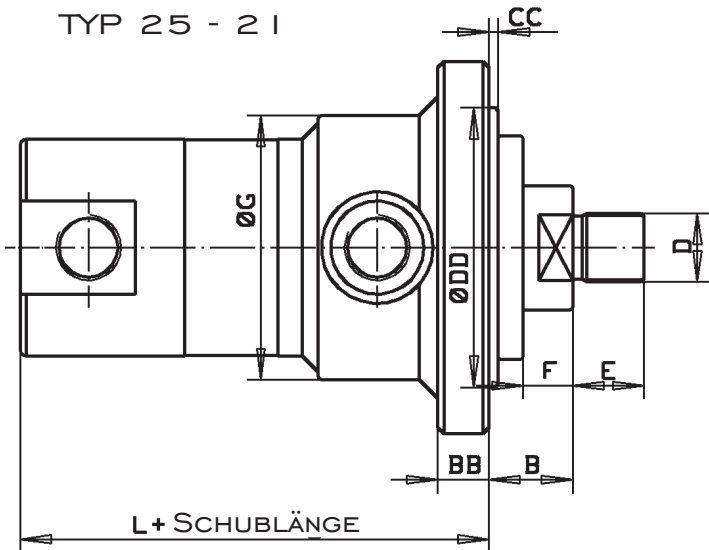

ÖLANSCHLUSS-U., HINTERSEITE.

TYP 25 - 2 I

LAGERBUCHSE MIT GEWINDE

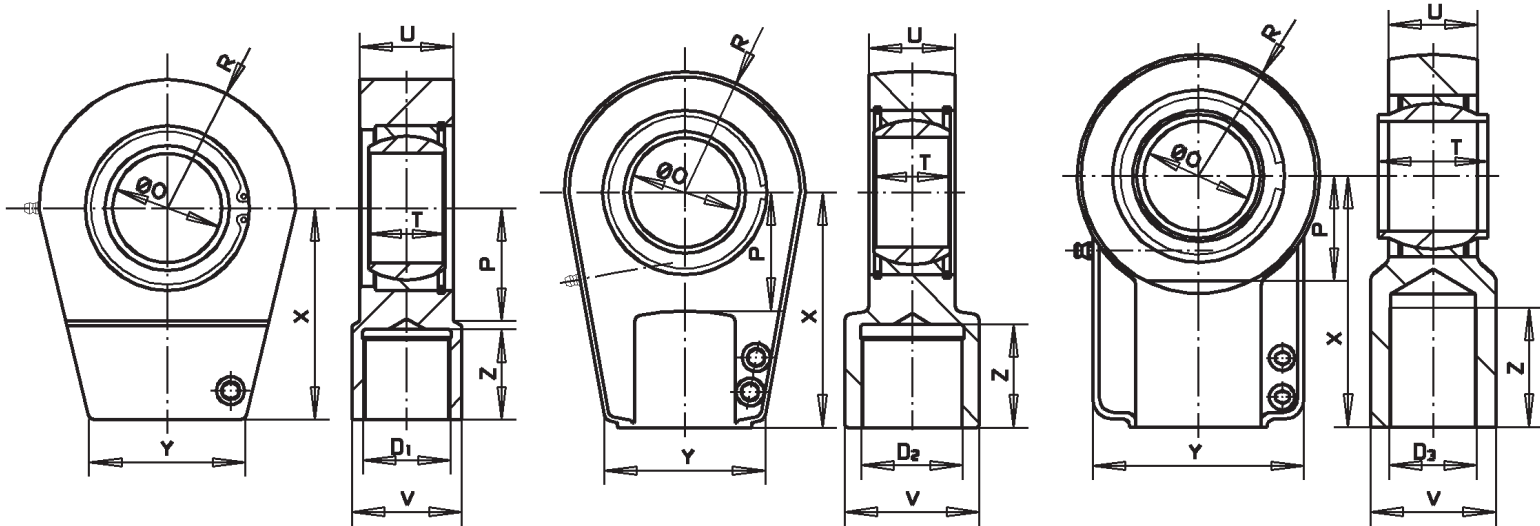

MIRO - XL

GIHR - K DO

GIHN - K LO

TYP	Ø O	D	X	Y	Z	V	P	T	U	R	SYL Ø
GIHN-K	12	M 12x1,25	38	32	17	16,5	14	12	10,6	16	25
GIHN-K	20	M 16x1,5	52	47	23	25	22	20	17	23,5	32
GIHR-K	20	M 16x1,5	50	41	17	25	25	16	19	28	32
GIHN-K	25	M 20x1,5	65	54	29	30	27	25	21	29	40
GIHR-K	25	M 16x1,5	50	41	17	25	25	20	23	28	40
GIHR-K	30	M 22x1,5	60	46	23	32	30	22	28	32	50
GIHR-K	30	M 22x1,5	60	46	23	32	30	22	28	32	60
GIHR-K	35	M 28x1,5	70	58	29	40	38	25	30	39	63
GIHN-K	40	M 33x2	97	80	46	47	41	40	32	44,5	70
GIHR-K	40	M 35x1,5	85	66	36	49	45	28	35	47	70
MIRO-XL	45	M 36x2	95	74	42	50	45	32	40	53	80
GIHN-K	50	M 42x2	120	96	57	58	50	50	40	54	90
GIHR-K	50	M 45x1,5	105	88	46	61	55	35	40	58	90
MIRO-XL	60	M 42x3	115	85	47	60	57	44	50	68	100
GIHR-K	60	M 58x1,5	130	90	59	75	65	44	50	65	100
MIRO-XL	60	M 42x3	115	85	47	60	57	44	50	68	110
GIHR-K	60	M 58x1,5	130	90	59	75	65	44	50	65	110
MIRO-XL	70	M 56x3	137	105	57	70	72	49	60	80	125
GIHN-K	70	M 56x2	160	135	76	80	70	70	57	77,5	125
GIHR-K	70	M 65x1,5	150	100	66	86	75	49	55	77	125
MIRO-XL	80	M 64x3	155	112	66	80	80	55	65	90	140
GIHN-K	80	M 64x3	180	148	86	90	78	80	66	84	140
GIHR-K	80	M 80x2	170	125	81	102	80	55	60	88	140
MIRO-XL	90	M 72x3	174	130	72	90	90	60	70	100	160
GIHN-K	90	M 72x3	195	160	91	100	85	90	72	92,5	160
GIHR-K	90	M 100x2	210	146	101	124	90	60	65	103	160

25-30/31

*OHNE SCHMIRNIPPEL.

Ø	A	B	C1	C2	C3	C4	D1	D2	D3	E1	E2	E3	F	G	H	I	J	K	L	M	O	R	S	U	Z	AA	BB	CC	DD	EE	FF	Ø
25*	149	130	12	14	16	-	M 12	-	M 12x1.25	20	-	16	10	48	35	R 1/4	25	32	45	38	12	19	29	12	19	70	12	3	55	75	9	25*
32	175	149	16	18	20	22	M 16x1.5	-	-	16	16	22	12	52	40	R 3/8	30	39	55	42	20	28	38	20	28	75	14	3	60	80	9	32
40	201	172	20	22	25	28	M 16x1.5	-	M 20x1.5	20	16	28	12	62	50	R 3/8	32	41	58	47	25	31	41	25	31	90	16	3	70	90	11	40
50	214	180	25	28	30	36	M 22x1.5	-	-	22	22	-	17	75	60	R 1/2	35	46	65	60	30	37	51	28	37	110	18	3	85	110	13	50
60	227	193	30	32	36	40	M 22x1.5	-	-	23	23	-	16	85	70	R 1/2	37	47	66	65	30	37	50	28	37	120	20	4	90	120	17	60
63	236	194	32	36	40	45	M 28x1.5	-	-	29	29	-	17	90	73	R 1/2	38	47	66	67	35	47	59	30	47	130	20	4	100	130	17	63
70	245	198	36	40	45	50	M 35x1.5	-	M 33x2	35	35	45	17	95	80	R 1/2	40	51	70	70	40	52	64	32	52	140	22	4	110	140	17	70
80	256	205	40	45	50	56	M 36x2	-	-	40	-	-	17	106	90	R 1/2	41	50	70	75	45	55	68	40	55	150	24	5	120	160	21	80
90	268	210	45	56	60	63	M 42x3	M 45x1.5	M 42x2	45	45	55	17	118	100	R 1/2	45	53	73	81	50	60	75	45	60	170	28	5	130	180	21	90
100	301	230	50	60	63	70	M 42x3	M 58x1.5	-	45	58	-	17	132	115	R 3/4	50	61	84	91	60	73	88	50	73	190	28	5	145	190	21	100
110	306	236	56	63	70	80	M 42x3	M 58x1.5	-	45	58	-	17	150	125	R 3/4	52	61	84	100	60	73	87	50	73	190	28	5	150	200	25	110
125	344	262	60	70	80	90	M 56x3	M 65x1.5	M 56x2	55	65	75	17	160	140	R 1	58	70	98	107	70	84	99	60	84	210	32	5	180	230	25	125
140	394	300	80	90	100	-	M 64x3	M 80x2	-	64	80	85	20	180	160	R 1	61	90	118	117	80	94	114	65	94	240	35	5	200	250	31	140
160	445	325	90	100	110	-	M 72x3	M 100x2	-	70	100	90	20	210	180	R 1¼	65	95	128	135	90	100	140	70	120	260	35	5	220	280	31	160

LAGERBUCHSE MIT GEWINDE SIND AUF DER NÄCHSTEN SEITE.

() = ZUSATZTEILE, WENN NÖTIG.

BESTELL BEISSPIEL

25 - 30 - 100 / 60 x 1000 - A - SS - 11 - (2 - 6)

DRUCKKLASSE

BEFESTIGUNGSTYP

INNENDURCHMESSER DES ZYLINDERS Ø

DURCHMESSER DER STANGE Ø C

SCHUBLÄNGE

SCHLAUCHANSCHLUSSTELLE AUF DER VONDERSEITE

SCHLAUCHANSCHLUSSTELLE AUF DER HINTERSEITE

SCHMIERNIPPELSTELLE AUF DER VONDERSEITE

ENTLUEFTUNGSSCHRAUBENSTELLE AUF DER VONDERSEITE

ENTLUEFTUNGSSCHRAUBENSTELLE AUF DER HINTERSEITE



TYP 25 - 30

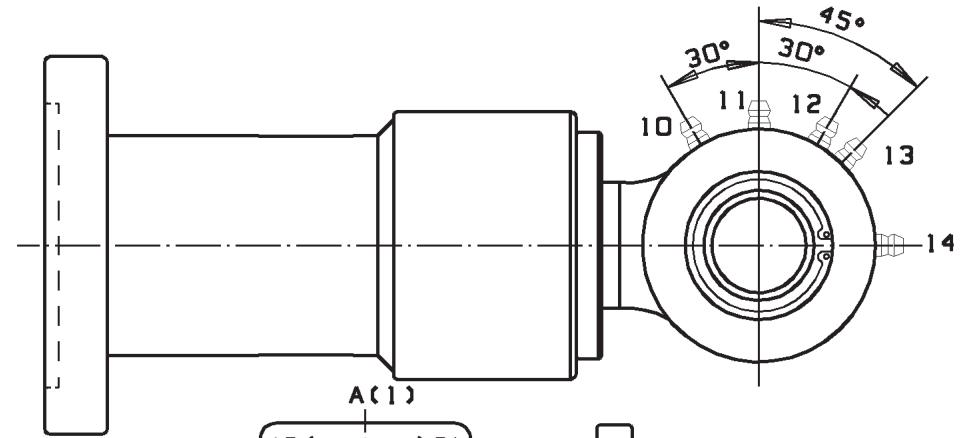
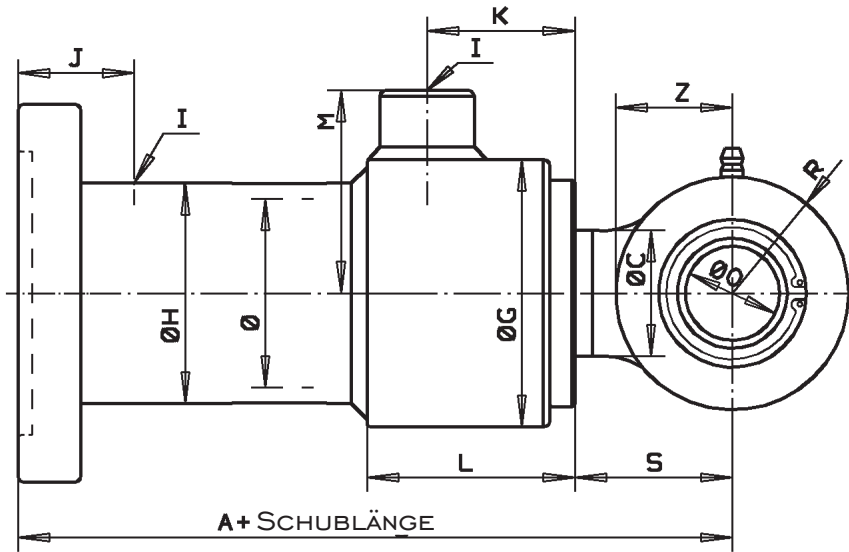

TYP 25 - 31

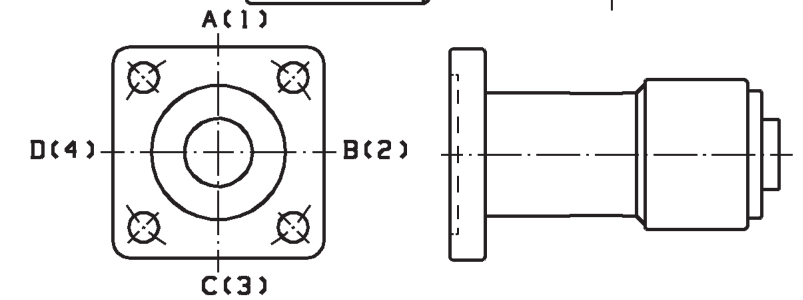
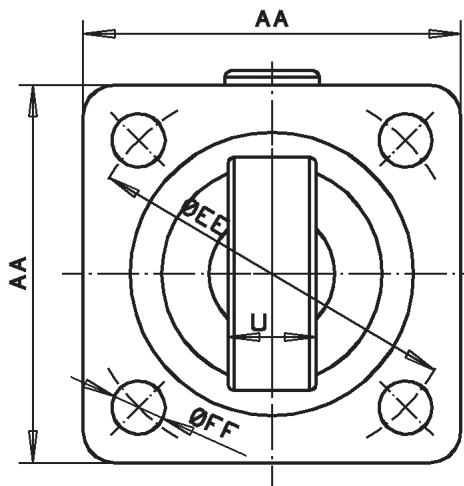
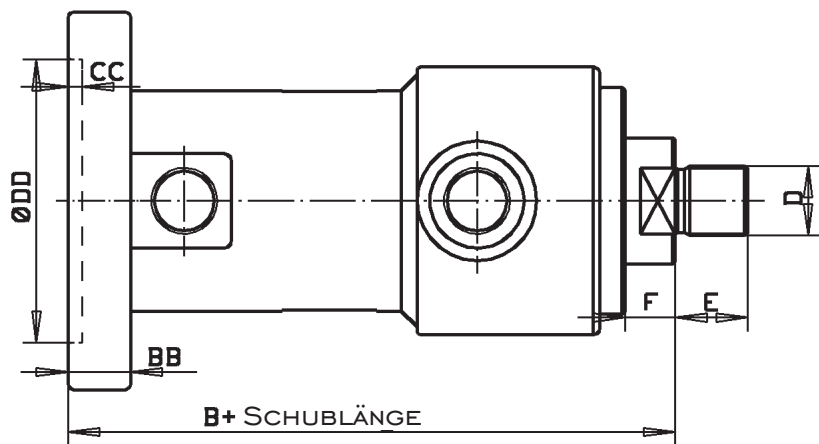

ÖLANSCHLUSS-U., VORDERSEITE.

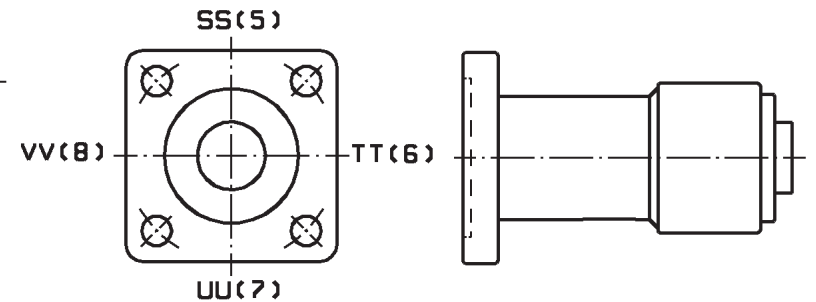

ÖLANSCHLUSS-U., HINTERSEITE.

TYP 25 - 31

LAGERBUCHSE MIT GEWINDE

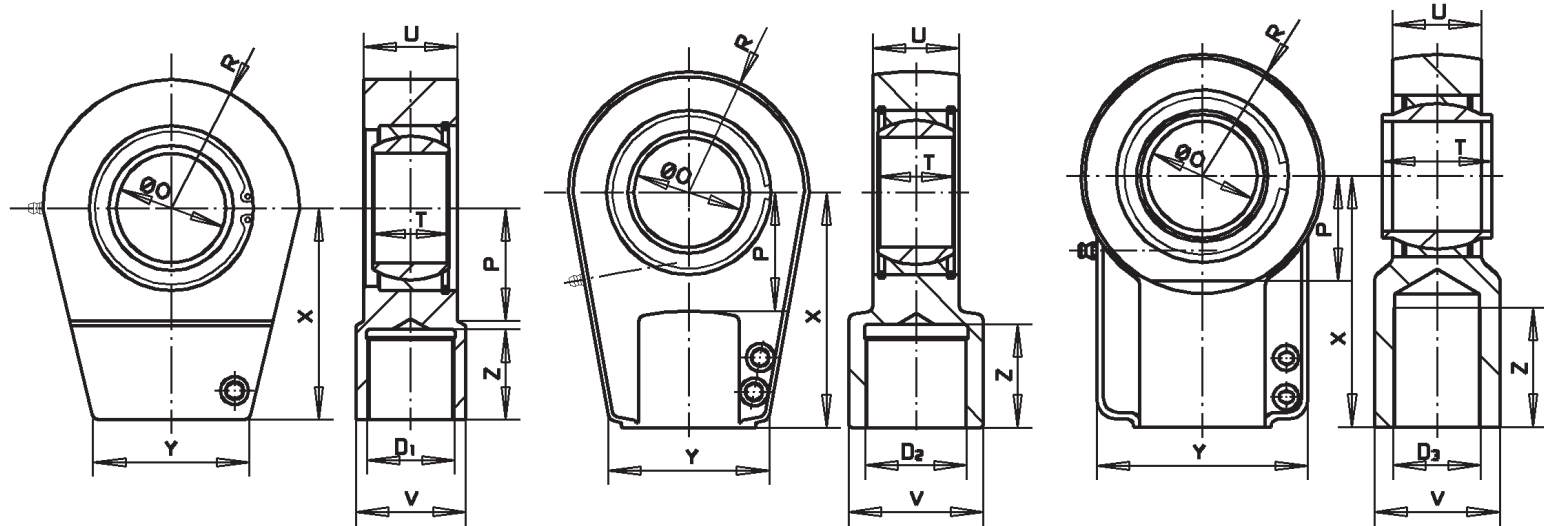

MIRO - XL

GIHR - K DO

GIHN - K LO

TYP	Ø O	D	X	Y	Z	V	P	T	U	R	SYL Ø
GIHN-K	12	M 12x1,25	38	32	17	16,5	14	12	10,6	16	25
GIHN-K	20	M 16x1,5	52	47	23	25	22	20	17	23,5	32
GIHR-K	20	M 16x1,5	50	41	17	25	25	16	19	28	32
GIHN-K	25	M 20x1,5	65	54	29	30	27	25	21	29	40
GIHR-K	25	M 16x1,5	50	41	17	25	25	20	23	28	40
GIHR-K	30	M 22x1,5	60	46	23	32	30	22	28	32	50
GIHR-K	30	M 22x1,5	60	46	23	32	30	22	28	32	60
GIHR-K	35	M 28x1,5	70	58	29	40	38	25	30	39	63
GIHN-K	40	M 33x2	97	80	46	47	41	40	32	44,5	70
GIHR-K	40	M 35x1,5	85	66	36	49	45	28	35	47	70
MIRO-XL	45	M 36x2	95	74	42	50	45	32	40	53	80
GIHN-K	50	M 42x2	120	96	57	58	50	50	40	54	90
GIHR-K	50	M 45x1,5	105	88	46	61	55	35	40	58	90
MIRO-XL	60	M 42x3	115	85	47	60	57	44	50	68	100
GIHR-K	60	M 58x1,5	130	90	59	75	65	44	50	65	100
MIRO-XL	60	M 42x3	115	85	47	60	57	44	50	68	110
GIHR-K	60	M 58x1,5	130	90	59	75	65	44	50	65	110
MIRO-XL	70	M 56x3	137	105	57	70	72	49	60	80	125
GIHN-K	70	M 56x2	160	135	76	80	70	70	57	77,5	125
GIHR-K	70	M 65x1,5	150	100	66	86	75	49	55	77	125
MIRO-XL	80	M 64x3	155	112	66	80	80	55	65	90	140
GIHN-K	80	M 64x3	180	148	86	90	78	80	66	84	140
GIHR-K	80	M 80x2	170	125	81	102	80	55	60	88	140
MIRO-XL	90	M 72x3	174	130	72	90	90	60	70	100	160
GIHN-K	90	M 72x3	195	160	91	100	85	90	72	92,5	160
GIHR-K	90	M 100x2	210	146	101	124	90	60	65	103	160

25-40/41

*OHNE SCHMIRNIPPEL.

Ø	A	B	C1	C2	C3	C4	D1	D2	D3	E1	E2	E3	F	G	H	I	J	K	L	M	O	R	S	U	Z	AA	BB	CC	DD	EE	Ø
25*	56	37	12	14	16	-	M 12	-	M 12x1.25	20	-	16	10	48	35	R 1/4	17	5	83	38	12	19	29	12	19	55	12	25	15	23	25*
32	76	50	16	18	20	22	M 16x1.5	-	-	16	16	22	12	52	40	R 3/8	14	1	82	42	20	28	38	20	28	60	15	30	20	26	32
40	81	52	20	22	25	28	M 16x1.5	-	M 20x1.5	20	16	28	12	70	50	R 3/8	20	1	108	51	25	31	41	25	31	70	18	30	25	35	40
50	91	57	25	28	30	36	M 22x1.5	-	-	22	22	-	17	75	60	R 1/2	22	6	110	60	30	37	51	28	37	80	20	40	30	38	50
60	92	58	30	32	36	40	M 22x1.5	-	-	23	23	-	16	90	70	R 1/2	22	5	120	67	30	37	50	28	37	100	20	40	30	45	60
63	101	59	32	36	40	45	M 28x1.5	-	-	29	29	-	17	90	73	R 1/2	22	5	119	67	35	47	59	30	47	110	25	45	35	45	63
70	106	59	36	40	45	50	M 35x1.5	-	M 33x2	35	35	45	17	100	80	R 1/2	23	9	122	72	40	52	64	32	52	120	25	50	40	50	70
80	113	62	40	45	50	56	M 36x2	-	-	40	-	-	17	115	90	R 1/2	22	5	124	80	45	55	68	40	55	130	30	50	40	58	80
90	120	62	45	56	60	63	M 42x3	M 45x1.5	M 42x2	45	45	55	17	125	100	R 1/2	23	8	126	85	50	60	75	45	60	140	30	50	40	63	90
100	141	70	50	60	63	70	M 42x3	M 58x1.5	-	45	58	-	17	132	115	R 3/4	28	8	138	91	60	73	88	50	73	160	40	63	50	66	100
110	140	70	56	63	70	80	M 42x3	M 58x1.5	-	45	58	-	17	150	125	R 3/4	28	8	143	100	60	73	87	50	73	170	40	60	50	75	110
125	162	80	60	70	80	90	M 56x3	M 65x1.5	M 56x2	55	65	75	17	170	140	R 1	36	7	160	112	70	84	99	60	84	190	50	70	60	85	125
140	189	95	80	90	100	-	M 64x3	M 80x2	-	64	80	85	20	190	160	R 1	36	15	180	122	80	94	114	65	94	210	60	80	70	95	140
160	223	103	90	100	110	-	M 72x3	M 100x2	-	70	100	90	20	222	180	R 1¼	40	12	197	141	90	100	140	70	120	240	60	90	75	111	160

LAGERBUCHSE MIT GEWINDE SIND AUF DER NÄCHSTEN SEITE.

() = ZUSATZTEILE, WENN NÖTIG.

BESTELL BEISSPIEL

25 - 40 - 100 / 60 x 1000 - A - SS - 11 - (2 - 6)

DRUCKKLASSE

BEFESTIGUNGSTYP

INNENDURCHMESSER DES ZYLINDERS Ø

DURCHMESSER DER STANGE Ø C

SCHUBLÄNGE

SCHLAUCHANSCHLUSSTELLE AUF DER VONDERSEITE

SCHLAUCHANSCHLUSSTELLE AUF DER HINTERSEITE

SCHMIERNIPPELSTELLE AUF DER VONDERSEITE

ENTLUEFTUNGSSCHRAUBENSTELLE AUF DER VONDERSEITE

ENTLUEFTUNGSSCHRAUBENSTELLE AUF DER HINTERSEITE

TYP 25 - 40

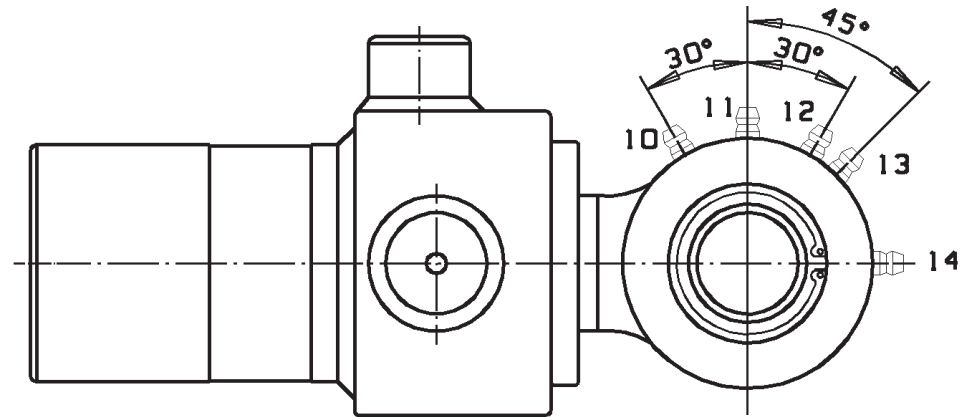
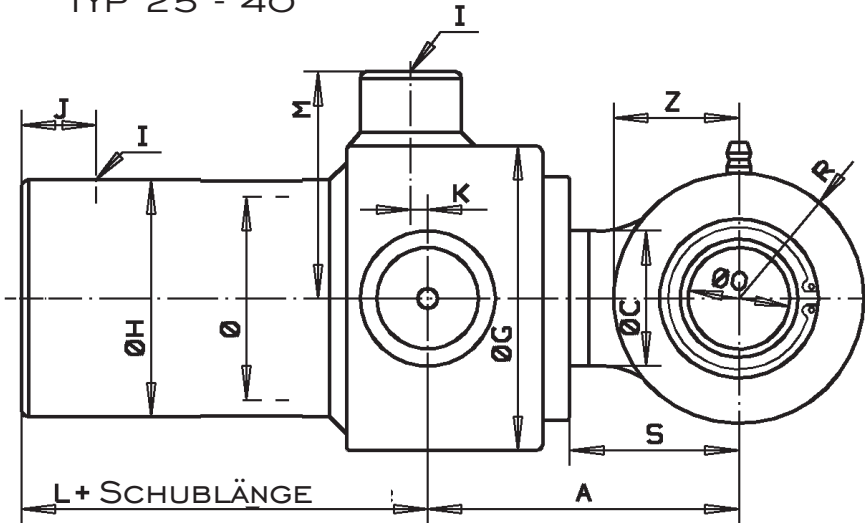

TYP 25 - 41

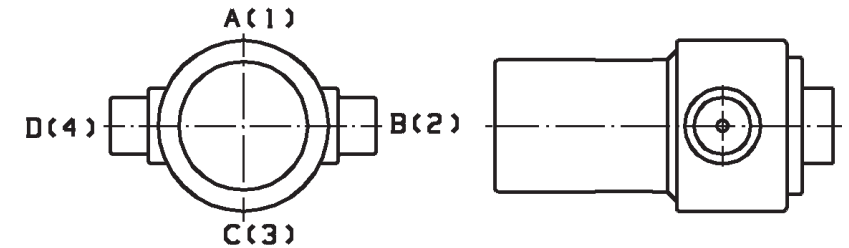
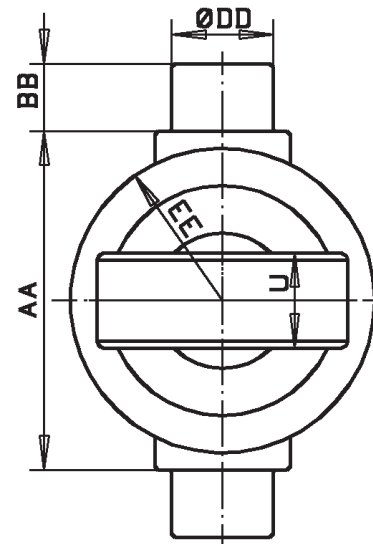
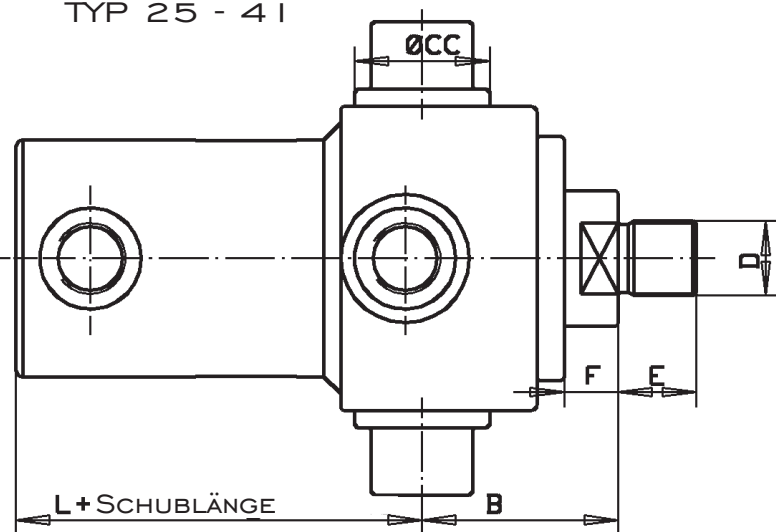

ÖLANSCHLUSS-U., VORDERSEITE.

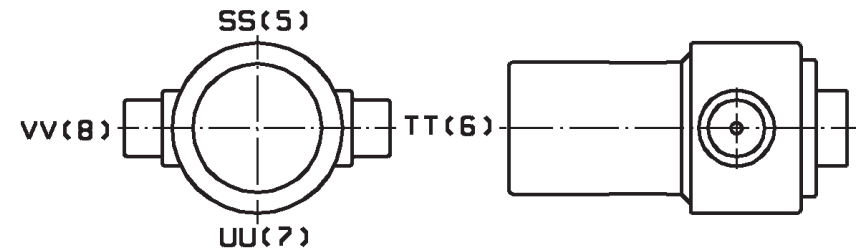

ÖLANSCHLUSS-U., HINTERSEITE.

TYP 25 - 4 I

LAGERBUCHSE MIT GEWINDE

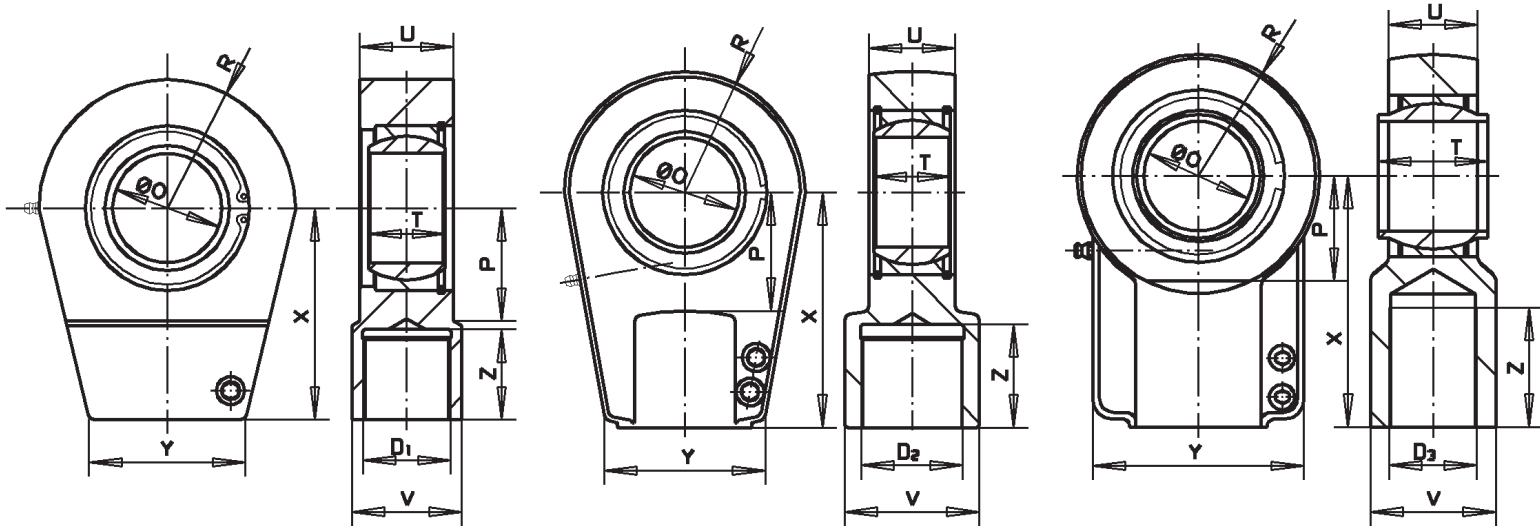

MIRO - XL

GIHR - K DO

GIHN - K LO

TYP	Ø O	D	X	Y	Z	V	P	T	U	R	SYL Ø
GIHN-K	12	M 12x1,25	38	32	17	16,5	14	12	10,6	16	25
GIHN-K	20	M 16x1,5	52	47	23	25	22	20	17	23,5	32
GIHR-K	20	M 16x1,5	50	41	17	25	25	16	19	28	32
GIHN-K	25	M 20x1,5	65	54	29	30	27	25	21	29	40
GIHR-K	25	M 16x1,5	50	41	17	25	25	20	23	28	40
GIHR-K	30	M 22x1,5	60	46	23	32	30	22	28	32	50
GIHR-K	30	M 22x1,5	60	46	23	32	30	22	28	32	60
GIHR-K	35	M 28x1,5	70	58	29	40	38	25	30	39	63
GIHN-K	40	M 33x2	97	80	46	47	41	40	32	44,5	70
GIHR-K	40	M 35x1,5	85	66	36	49	45	28	35	47	70
MIRO-XL	45	M 36x2	95	74	42	50	45	32	40	53	80
GIHN-K	50	M 42x2	120	96	57	58	50	50	40	54	90
GIHR-K	50	M 45x1,5	105	88	46	61	55	35	40	58	90
MIRO-XL	60	M 42x3	115	85	47	60	57	44	50	68	100
GIHR-K	60	M 58x1,5	130	90	59	75	65	44	50	65	100
MIRO-XL	60	M 42x3	115	85	47	60	57	44	50	68	110
GIHR-K	60	M 58x1,5	130	90	59	75	65	44	50	65	110
MIRO-XL	70	M 56x3	137	105	57	70	72	49	60	80	125
GIHN-K	70	M 56x2	160	135	76	80	70	70	57	77,5	125
GIHR-K	70	M 65x1,5	150	100	66	86	75	49	55	77	125
MIRO-XL	80	M 64x3	155	112	66	80	80	55	65	90	140
GIHN-K	80	M 64x3	180	148	86	90	78	80	66	84	140
GIHR-K	80	M 80x2	170	125	81	102	80	55	60	88	140
MIRO-XL	90	M 72x3	174	130	72	90	90	60	70	100	160
GIHN-K	90	M 72x3	195	160	91	100	85	90	72	92,5	160
GIHR-K	90	M 100x2	210	146	101	124	90	60	65	103	160

TYP B

B-10/11

Ø	A	B	C1	C2	C3	D1	D2	D3	E	F	G	H	I	J	K	L	O	P	R	S	U	Z	Ø
63	272	230	30	36	40	M 28x1.5	-	-	29	9	100	73	R 1/2	69	56	78	35	39	47	51	30	47	63
80	292	241	40	50	56	M 36x2	-	-	40	6	122	90	R 1/2	77	57	81	45	46	55	57	40	55	80
100	362	291	50	60	70	M 42x3	M 58x1.5	-	45	5	150	115	R 3/4	101	79	105	60	63	73	76	50	73	100
125	416	334	60	70	90	M 56x3	M 65x1.5	M 56x2	55	5	180	140	R 1	120	89	120	70	74	84	87	60	84	125
140	468	374	80	90	100	M 64x3	M 80x2	M 64x3	64	8	200	160	R 1	130	102	135	80	84	94	102	65	94	140
160	545	425	90	100	110	M 72x3	M 100x2	M 72x3	70	4	224	180	R 1¼	160	114	149	90	90	100	124	70	120	160
180	600	473	100	110	125	M 80x4	M 110x2	M 80x3	80	7	250	200	R 1¼	160	124	157	100	105	115	134	80	120	180
200	670	532	110	125	140	M 90x4	M 120x3	M 90x3	90	12	280	225	R 1¼	185	152	185	110	120	125	150	80	140	200
250	854	650	125	140	160	M 110x4	-	-	100	5	343	280	R 1¼	270	161	200	140	160	178	209	100	205	250
320	956	709	140	160	180	M 125x4	-	-	125	2	440	368	R 1¼	278	195	240	160	180	208	249	120	224	320

LAGERBUCHSE MIT GEWINDE SIND AUF DER NÄCHSTEN SEITE.

() = ZUSATZTEILE, WENN NÖTIG.

BESTELL BEISSPIEL

B - 10 - 100 / 60 x 1000 - A - SS - 11 - 2 - (2 - 6)

DRUCKKLASSE

BEFESTIGUNGSTYP

INNENDURCHMESSER DES ZYLINDERS Ø

DURCHMESSER DER STANGE Ø C

SCHUBLÄNGE

SCHLAUCHANSCHLUSSTELLE AUF DER VONDERSEITE

SCHLAUCHANSCHLUSSTELLE AUF DER HINTERSEITE

SCHMIERNIPPELSTELLE AUF DER VONDERSEITE

SCHMIERNIPPELSTELLE AUF DER HINTERSEITE

ENTLUEFTUNGSSCHRAUBENSTELLE AUF DER VONDERSEITE

ENTLUEFTUNGSSCHRAUBENSTELLE AUF DER HINTERSEITE

TYP B - IO

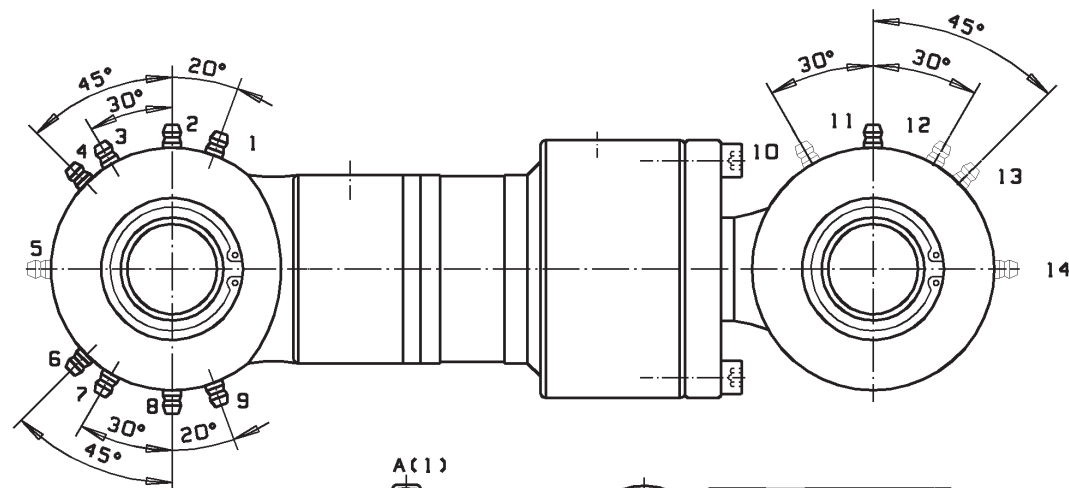
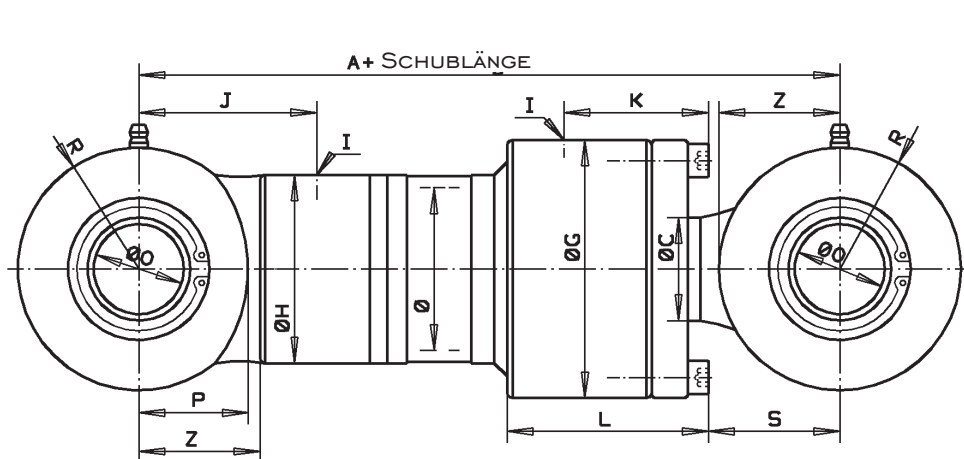

TYP B - II

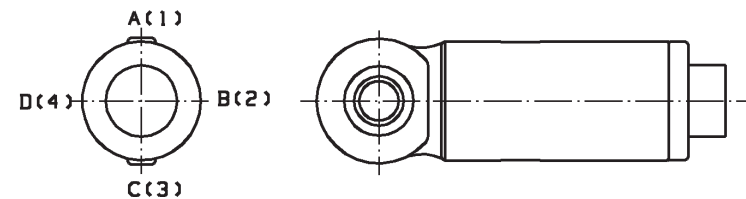
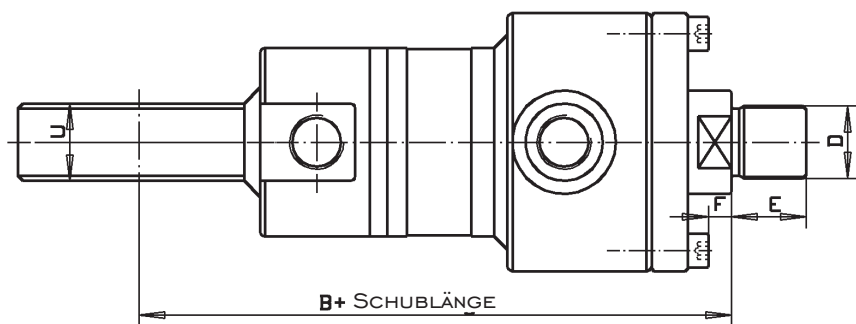

ÖLANSCHLUSS-U., VORDERSEITE.

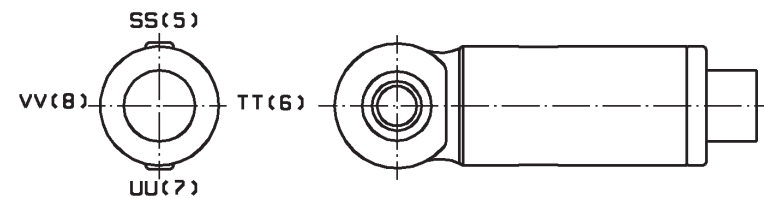

ÖLANSCHLUSS-U., HINTERSEITE.

TYP B - I I

LAGERBUCHSE MIT GEWINDE

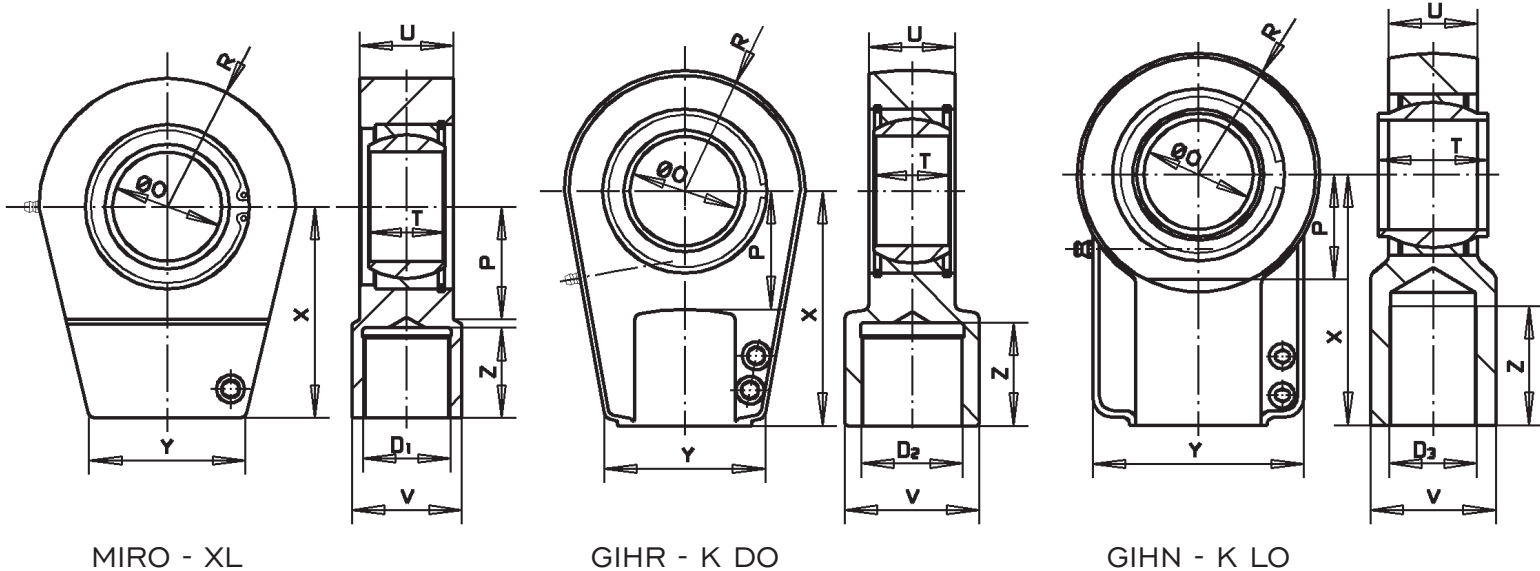

TYP	Ø O	D	X	Y	Z	V	P	T	U	R	SYL Ø
GIHR-K	35	M 28x1,5	70	58	29	40	38	25	30	39	63
MIRO-XL	45	M 36x2	95	74	42	50	45	32	40	53	80
MIRO-XL	60	M 42x3	115	85	47	60	57	44	50	68	100
GIHR-K	60	M 58x1,5	130	90	59	75	65	44	50	65	100
MIRO-XL	70	M 56x3	137	105	57	70	72	49	60	80	125
GIHN-K	70	M 56x2	160	135	76	80	70	70	57	77,5	125
GIHR-K	70	M 65x1,5	150	100	66	86	75	49	55	77	125
MIRO-XL	80	M 64x3	155	112	66	80	80	55	65	90	140
GIHN-K	80	M 64x3	180	148	86	90	78	80	66	84	140
GIHR-K	80	M 80x2	170	125	81	102	80	55	60	88	140
MIRO-XL	90	M 72x3	174	130	72	90	90	60	70	100	160
GIHN-K	90	M 72x3	195	160	91	100	85	90	72	92,5	160
GIHR-K	90	M 100x2	210	146	101	124	90	60	65	103	160
MIRO-XL	100	M 80x4	200	150	85	100	100	70	80	110	180
GIHN-K	100	M 80x3	210	178	96	110	98	100	84	105	180
GIHR-K	100	M 110x2	235	166	111	138	105	70	70	115	180
MIRO-XL	110	M 90x4	230	150	95	120	115	70	80	125	200
GIHN-K	110	M 90x3	235	190	106	125	105	110	88	117,5	200
GIHR-K	110	M 120x3	265	190	125	152	115	70	80	132,5	200
MIRO-XL	140	M 110x4	260	200	110	150	125	90	100	162	250
GIHN-K	160	M 125x4	310	250	126	165	150	160	130	163	320

B-20/2 I

Ø	A	B	C1	C2	C3	D1	D2	D3	E	F	G	H	I	J	K	L	O	R	S	U	Z	AA	BB	CC	DD	EE	FF	Ø
63	75	33	30	36	40	M 28x1.5	-	-	29	9	100	73	R 1/2	22	41	159	35	47	51	30	47	140	18	2	110	140	17	63
80	88	38	40	50	56	M 36x2	-	-	40	7	122	90	R 1/2	22	43	166	45	55	57	40	55	160	20	3	132	170	21	80
100	117	46	50	60	70	M 42x3	M 58x1.5	-	45	5	150	115	R 3/4	28	49	183	60	73	76	50	73	190	25	4	164	200	21	100
125	133	51	60	70	90	M 56x3	M 65x1.5	M 56x2	55	5	180	140	R 1	36	60	216	70	84	87	60	84	220	29	4	195	240	25	125
140	152	58	80	90	100	M 64x3	M 80x2	M 64x3	64	8	200	160	R 1	36	62	232	80	94	102	65	94	252	30	5	211	267	31	140
160	179	59	90	100	110	M 72x3	M 100x2	M 72x3	70	4	224	180	R 1¼	40	71	258	90	100	124	70	120	275	34	4	244	297	31	160
180	195	68	100	110	125	M 80x4	M 110x2	M 80x3	80	7	250	200	R 1¼	40	82	305	100	115	134	80	120	320	43	5	274	335	37	180
200	214	76	110	125	140	M 90x4	M 120x3	M 90x3	90	12	280	225	R 1¼	45	88	316	110	125	150	80	140	350	45	4	295	370	43	200
250	285	81	125	140	160	M 110x4	-	-	100	5	343	280	R 1¼	65	105	384	140	178	209	100	205	400	60	6	360	445	49	250
320	328	81	140	160	180	M 125x4	-	-	125	2	440	368	R 1¼	54	141	429	160	208	249	120	224	520	90	5	460	560	60	320

LAGERBUCHSE MIT GEWINDE SIND AUF DER NÄCHSTEN SEITE.

() = ZUSATZTEILE, WENN NÖTIG.

THBESTELL BEISSPIEL

B - 20 - 100 / 60 x 1000 - A - SS - 11 - (2 - 6)

DRUCKKLASSE

BEFESTIGUNGSTYP

INNENDURCHMESSER DES ZYLINDERS Ø

DURCHMESSER DER STANGE Ø C

SCHUBLÄNGE

SCHLAUCHANSCHLUSSTELLE AUF DER VONDERSEITE

SCHLAUCHANSCHLUSSTELLE AUF DER HINTERSEITE

SCHMIERNIPPELSTELLE AUF DER VONDERSEITE

ENTLUEFTUNGSSCHRAUBENSTELLE AUF DER VONDERSEITE

ENTLUEFTUNGSSCHRAUBENSTELLE AUF DER HINTERSEITE

TYP B - 20

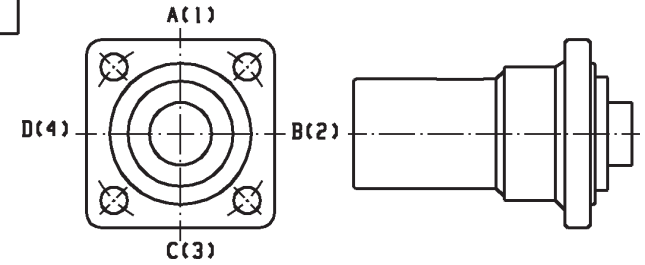
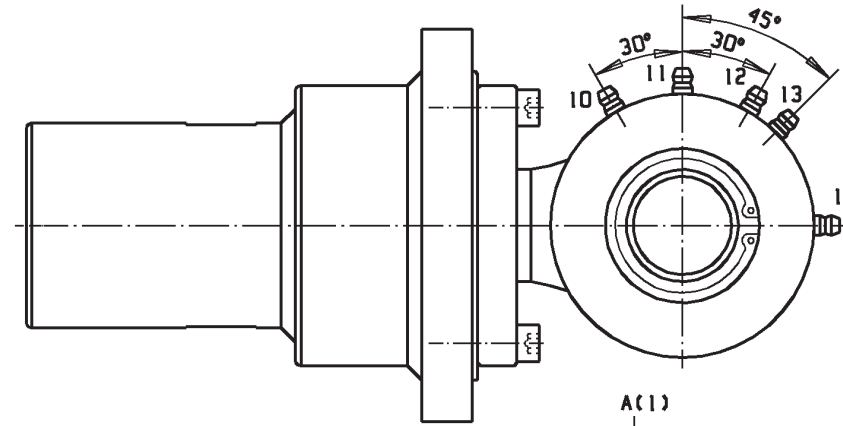
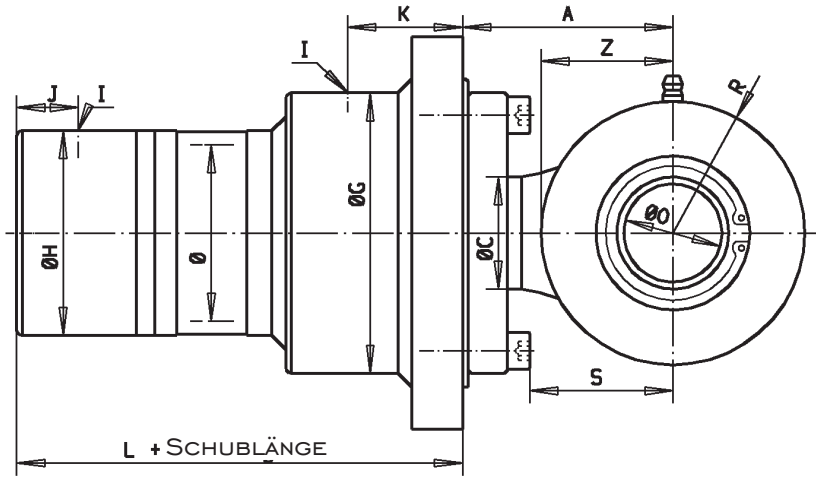

TYP B - 21

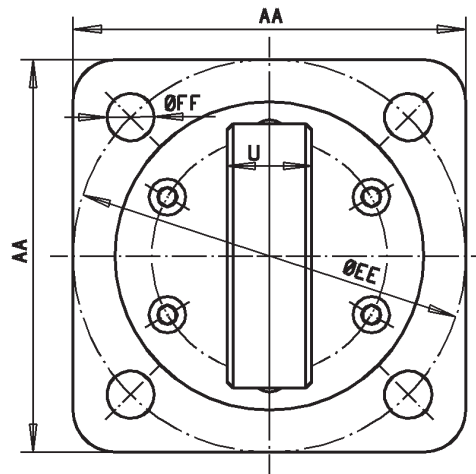
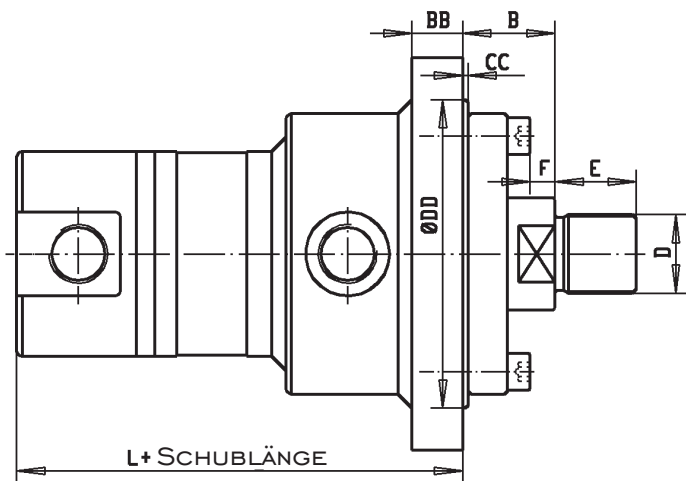

ÖLANSCHLUSS-U., VORDERSEITE.

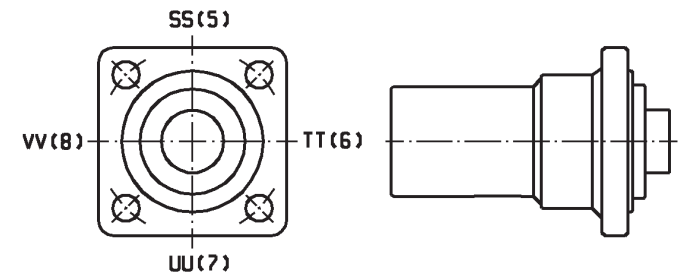

ÖLANSCHLUSS-U., HINTERSEITE.

TYP B - 2 I

LAGERBUCHSE MIT GEWINDE

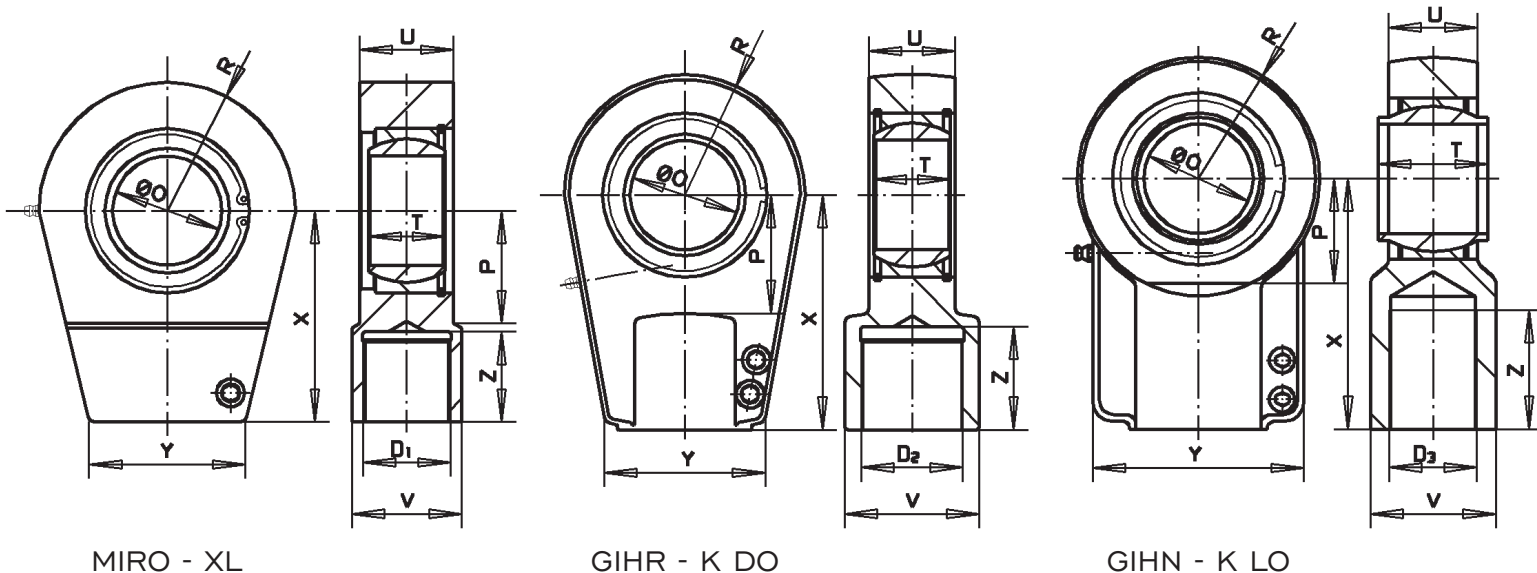

MIRO - XL

GIHR - K DO

GIHN - K LO

TYP	Ø O	D	X	Y	Z	V	P	T	U	R	SYL Ø
GIHR-K	35	M 28x1,5	70	58	29	40	38	25	30	39	63
MIRO-XL	45	M 36x2	95	74	42	50	45	32	40	53	80
MIRO-XL	60	M 42x3	115	85	47	60	57	44	50	68	100
GIHR-K	60	M 58x1,5	130	90	59	75	65	44	50	65	100
MIRO-XL	70	M 56x3	137	105	57	70	72	49	60	80	125
GIHN-K	70	M 56x2	160	135	76	80	70	70	57	77,5	125
GIHR-K	70	M 65x1,5	150	100	66	86	75	49	55	77	125
MIRO-XL	80	M 64x3	155	112	66	80	80	55	65	90	140
GIHN-K	80	M 64x3	180	148	86	90	78	80	66	84	140
GIHR-K	80	M 80x2	170	125	81	102	80	55	60	88	140
MIRO-XL	90	M 72x3	174	130	72	90	90	60	70	100	160
GIHN-K	90	M 72x3	195	160	91	100	85	90	72	92,5	160
GIHR-K	90	M 100x2	210	146	101	124	90	60	65	103	160
MIRO-XL	100	M 80x4	200	150	85	100	100	70	80	110	180
GIHN-K	100	M 80x3	210	178	96	110	98	100	84	105	180
GIHR-K	100	M 110x2	235	166	111	138	105	70	70	115	180
MIRO-XL	110	M 90x4	230	150	95	120	115	70	80	125	200
GIHN-K	110	M 90x3	235	190	106	125	105	110	88	117,5	200
GIHR-K	110	M 120x3	265	190	125	152	115	70	80	132,5	200
MIRO-XL	140	M 110x4	260	200	110	150	125	90	100	162	250
GIHN-K	160	M 125x4	310	250	126	165	150	160	130	163	320

B-30/3 I

Ø	A	B	C1	C2	C3	D1	D2	D3	E	F	G	H	I	J	K	L	O	R	S	U	Z	AA	BB	CC	DD	EE	FF	Ø
63	241	199	30	36	40	M 28x1.5	-	-	29	9	100	73	R 1/2	38	56	78	35	47	51	30	47	130	20	4	100	130	17	63
80	256	205	40	50	56	M 36x2	-	-	40	6	122	90	R 1/2	41	57	81	45	55	57	40	55	150	24	5	120	160	21	80
100	311	240	50	60	70	M 42x3	M 58x1.5	-	45	5	150	115	R 3/4	50	79	105	60	73	76	50	73	190	28	6	145	190	21	100
125	354	272	60	70	90	M 56x3	M 65x1.5	M 56x2	55	5	180	140	R 1	58	89	120	70	84	87	60	84	210	32	5	180	230	25	125
140	399	305	80	90	100	M 64x3	M 80x2	M 64x3	64	8	200	160	R 1	61	102	135	80	94	102	65	94	240	35	6	200	250	31	140
160	450	330	90	100	110	M 72x3	M 100x2	M 72x3	70	4	224	180	R 1¼	65	114	149	90	100	124	70	120	260	35	6	220	280	31	160
180	511	384	100	110	125	M 80x4	M 110x2	M 80x3	80	7	250	200	R 1¼	71	124	157	100	115	134	80	120	300	40	5	250	320	37	180
200	555	417	110	125	140	M 90x4	M 120x3	M 90x3	90	12	280	225	R 1¼	70	152	185	110	125	150	80	140	340	40	5	270	350	44	200
250	694	490	125	140	160	M 110x4	-	-	100	5	343	280	R 1¼	110	161	200	140	178	209	100	205	390	58	6	330	430	46	250
320	810	563	140	160	180	M 125x4	-	-	125	2	440	368	R 1¼	132	195	240	160	208	249	120	224	520	88	8	440	560	60	320

LAGERBUCHSE MIT GEWINDE SIND AUF DER NÄCHSTEN SEITE.

() = ZUSATZTEILE, WENN NÖTIG.

BESTELL BEISSPIEL

B - 30 - 100 / 60 x 1000 - A - SS - 11 - (2 - 6)

DRUCKKLASSE

BEFESTIGUNGSTYP

INNENDURCHMESSER DES ZYLINDERS Ø

DURCHMESSER DER STANGE Ø C

SCHUBLÄNGE

SCHLAUCHANSCHLUSSTELLE AUF DER VONDERSEITE

SCHLAUCHANSCHLUSSTELLE AUF DER HINTERSEITE

SCHMIERNIPPELSTELLE AUF DER VONDERSEITE

ENTLUEFTUNGSSCHRAUBENSTELLE AUF DER VONDERSEITE

ENTLUEFTUNGSSCHRAUBENSTELLE AUF DER HINTERSEITE

TYP B - 30

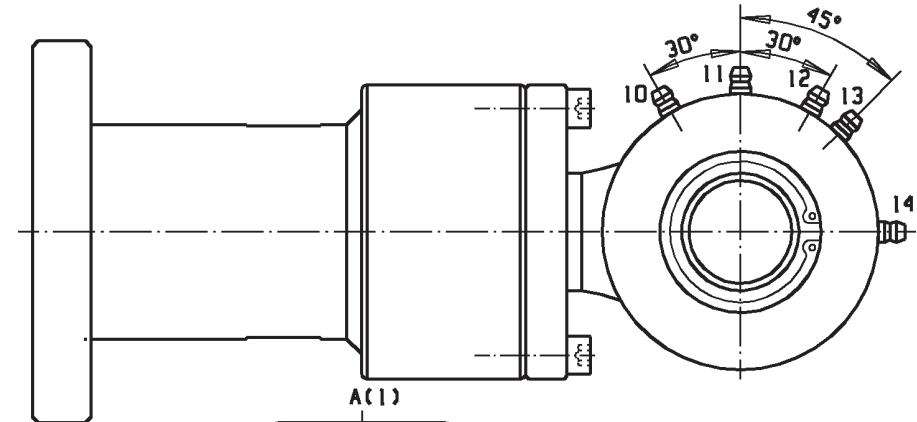
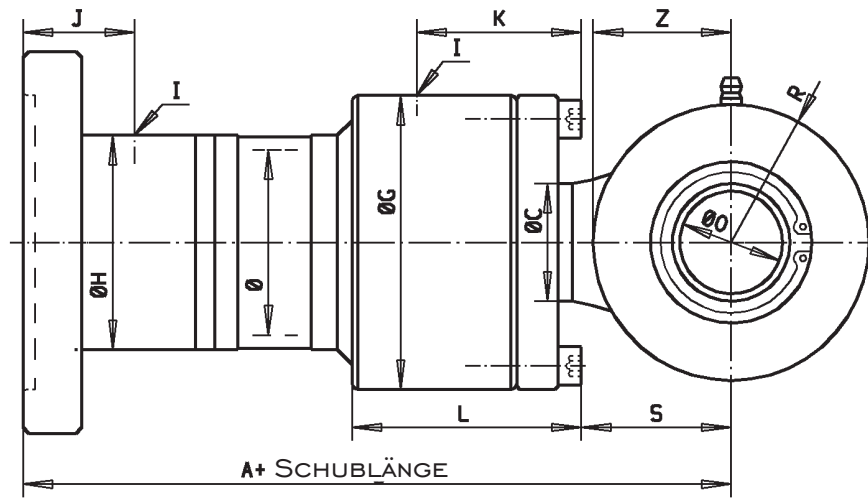

TYP B - 31

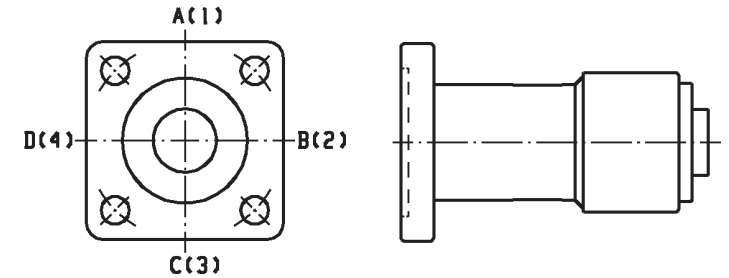
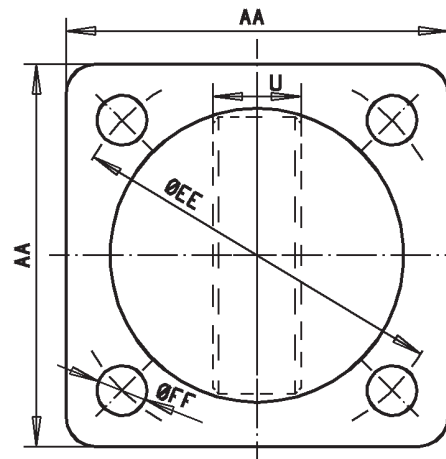
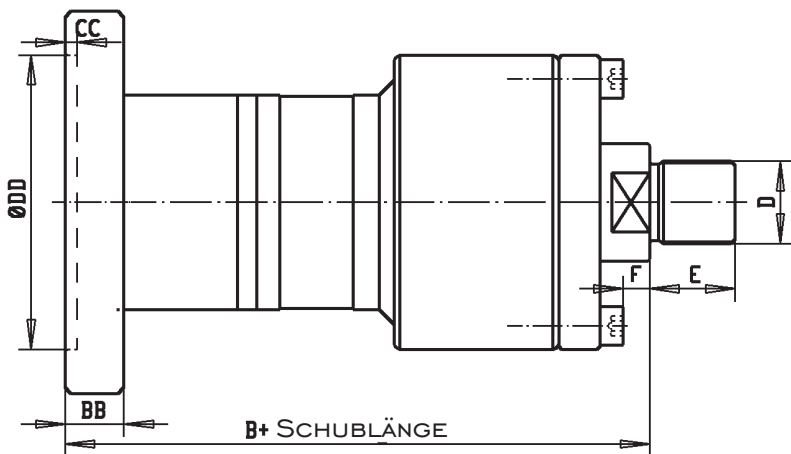

ÖLANSCHLUSS-U., VORDERSEITE.

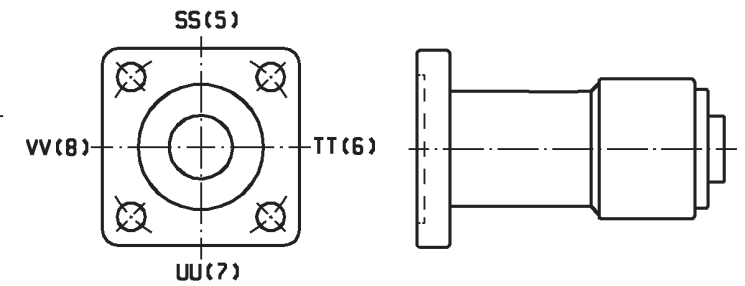

ÖLANSCHLUSS-U., HINTERSEITE.

TYP B - 3 I

LAGERBUCHSE MIT GEWINDE

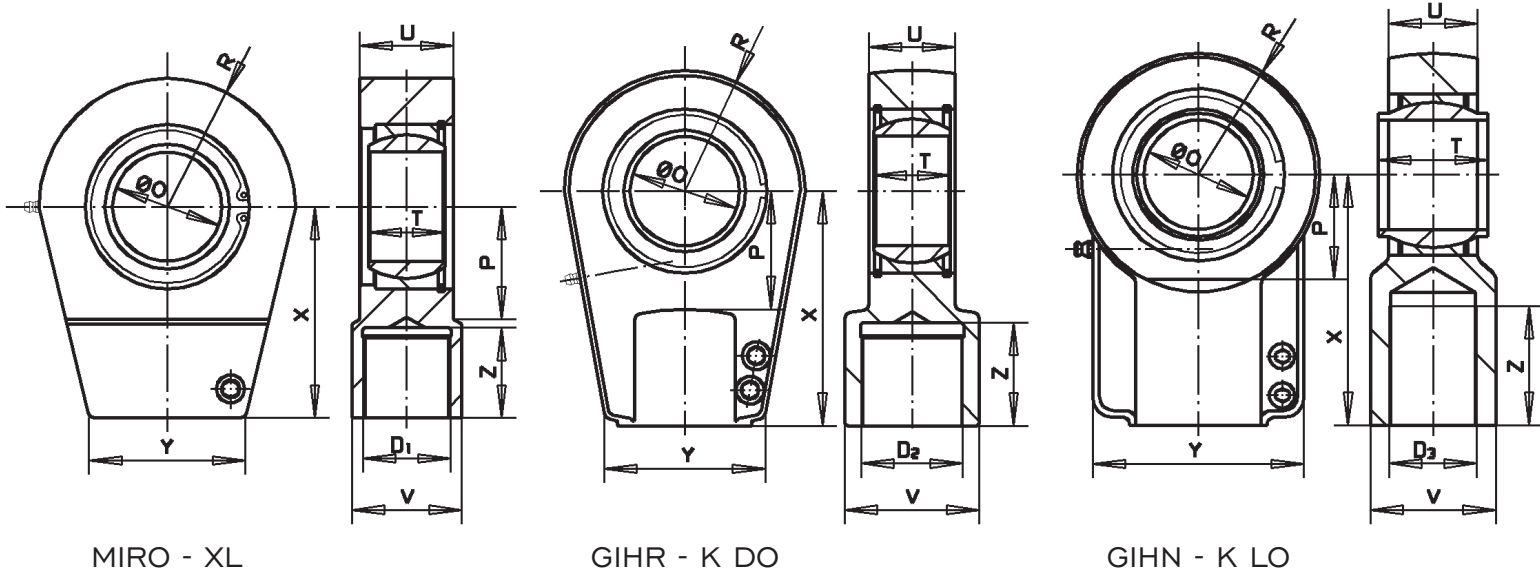

TYP	Ø O	D	X	Y	Z	V	P	T	U	R	SYL Ø
GIHR-K	35	M 28x1,5	70	58	29	40	38	25	30	39	63
MIRO-XL	45	M 36x2	95	74	42	50	45	32	40	53	80
MIRO-XL	60	M 42x3	115	85	47	60	57	44	50	68	100
GIHR-K	60	M 58x1,5	130	90	59	75	65	44	50	65	100
MIRO-XL	70	M 56x3	137	105	57	70	72	49	60	80	125
GIHN-K	70	M 56x2	160	135	76	80	70	70	57	77,5	125
GIHR-K	70	M 65x1,5	150	100	66	86	75	49	55	77	125
MIRO-XL	80	M 64x3	155	112	66	80	80	55	65	90	140
GIHN-K	80	M 64x3	180	148	86	90	78	80	66	84	140
GIHR-K	80	M 80x2	170	125	81	102	80	55	60	88	140
MIRO-XL	90	M 72x3	174	130	72	90	90	60	70	100	160
GIHN-K	90	M 72x3	195	160	91	100	85	90	72	92,5	160
GIHR-K	90	M 100x2	210	146	101	124	90	60	65	103	160
MIRO-XL	100	M 80x4	200	150	85	100	100	70	80	110	180
GIHN-K	100	M 80x3	210	178	96	110	98	100	84	105	180
GIHR-K	100	M 110x2	235	166	111	138	105	70	70	115	180
MIRO-XL	110	M 90x4	230	150	95	120	115	70	80	125	200
GIHN-K	110	M 90x3	235	190	106	125	105	110	88	117,5	200
GIHR-K	110	M 120x3	265	190	125	152	115	70	80	132,5	200
MIRO-XL	140	M 110x4	260	200	110	150	125	90	100	162	250
GIHN-K	160	M 125x4	310	250	126	165	150	160	130	163	320

B-40/4 I

Ø	A	B	C ₁	C ₂	C ₃	D ₁	D ₂	D ₃	E	F	G	H	I	J	K	L	O	R	S	U	Z	AA	BB	CC	DD	EE	Ø
63	105	63	30	36	40	M 28x1.5	-	-	29	9	100	73	R 1/2	22	2	120	35	47	51	30	47	110	25	45	35	50	63
80	113	62	40	50	56	M 36x2	-	-	40	6	122	90	R 1/2	22	1	124	45	55	57	40	55	130	30	50	40	61	80
100	150	79	50	60	70	M 42x3	M 58x1.5	-	45	5	150	115	R 3/4	28	5	139	60	73	76	50	73	160	40	60	50	75	100
125	172	90	60	70	90	M 56x3	M 65x1.5	M 56x2	55	5	180	140	R 1	36	4	160	70	84	87	60	84	190	50	70	60	90	125
140	194	100	80	90	100	M 64x3	M 80x2	M 64x3	64	8	200	160	R 1	36	10	180	80	94	102	65	94	210	60	80	70	100	140
160	228	108	90	100	110	M 72x3	M 100x2	M 72x3	70	4	224	180	R 1¼	40	10	197	90	100	124	70	120	240	60	90	75	112	160
180	240	113	100	110	125	M 80x4	M 110x2	M 80x3	80	7	265	200	R 1¼	40	17	240	100	115	134	80	120	270	70	100	90	133	180
200	280	142	110	125	140	M 90x4	M 120x3	M 90x3	90	12	295	225	R 1¼	45	22	250	110	125	150	80	140	300	80	110	100	148	200
250	344	140	125	140	160	M 110x4	-	-	100	5	353	280	R 1¼	65	26	305	140	178	209	100	205	360	90	130	110	177	250
320	424	177	140	160	180	M 125x4	-	-	125	2	440	368	R 1¼	54	45	333	160	208	249	120	224	470	125	180	160	220	320

LAGERBUCHSE MIT GEWINDE SIND AUF DER NÄCHSTEN SEITE.

() = ZUSATZTEILE, WENN NÖTIG.

BESTELL BEISSPIEL

B - 40 - 100 / 60 x 1000 - A - SS - 11 - (2 - 6)

DRUCKKLASSE

BEFESTIGUNGSTYP

INNENDURCHMESSER DES ZYLINDERS Ø

DURCHMESSER DER STANGE Ø C

SCHUBLÄNGE

SCHLAUCHANSCHLUSSTELLE AUF DER VONDERSEITE

SCHLAUCHANSCHLUSSTELLE AUF DER HINTERSEITE

SCHMIERNIPPELSTELLE AUF DER VONDERSEITE

ENTLUEFTUNGSSCHRAUBENSTELLE AUF DER VONDERSEITE

ENTLUEFTUNGSSCHRAUBENSTELLE AUF DER HINTERSEITE

TYP B - 40

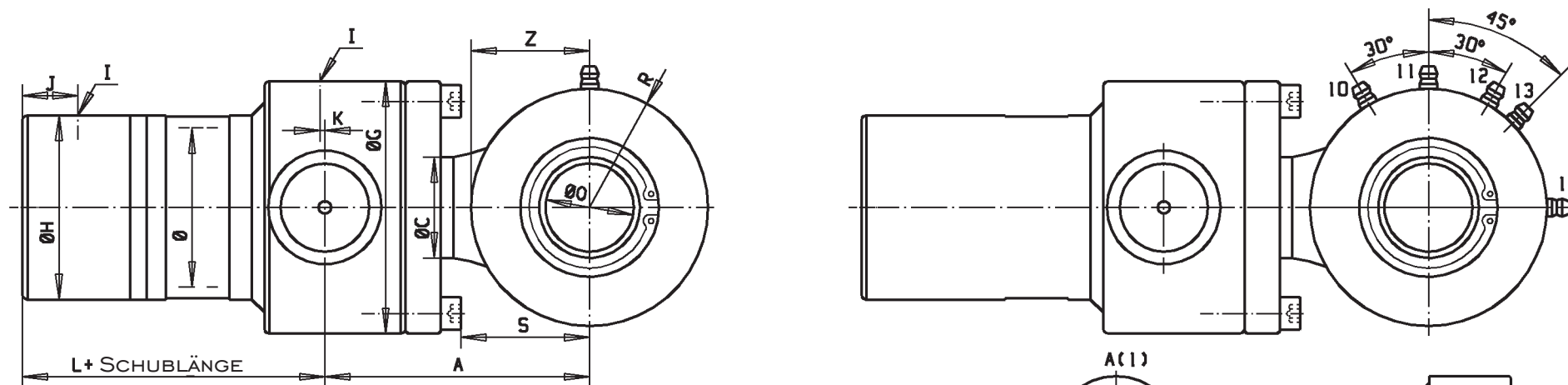

TYP B - 41

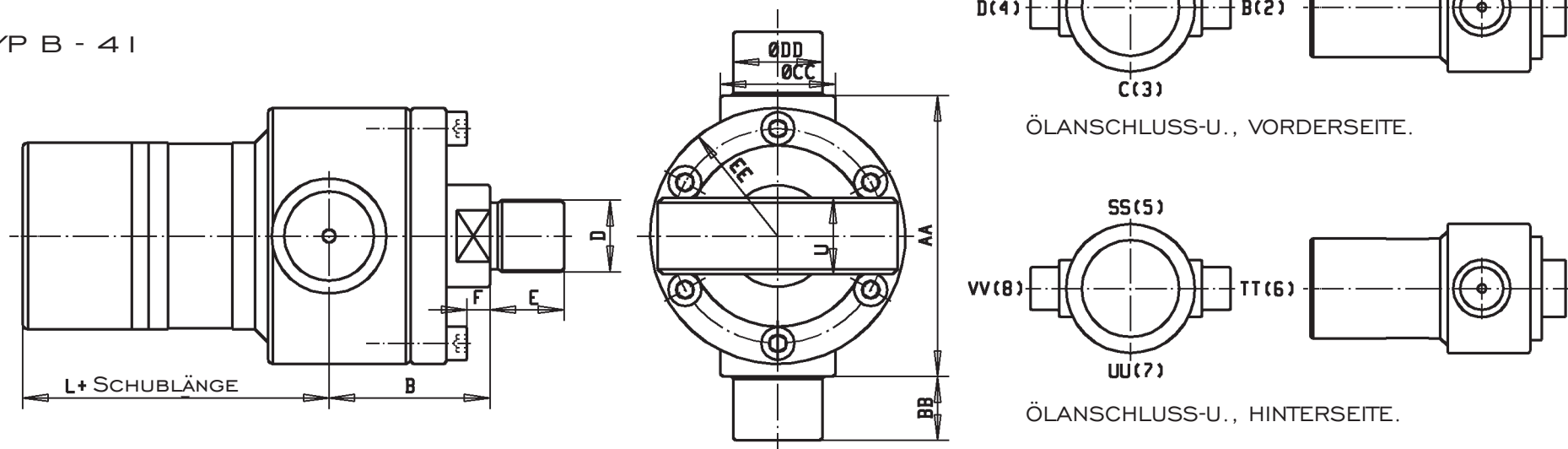

TYP B - 4 I

LAGERBUCHSE MIT GEWINDE

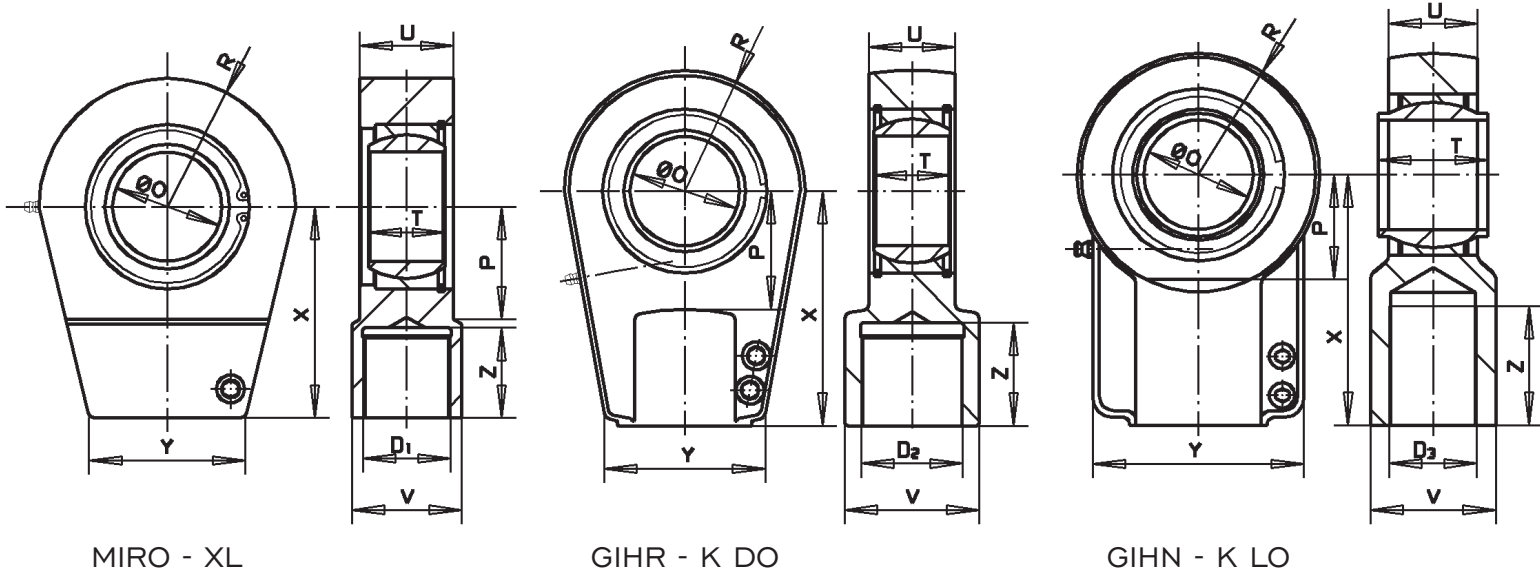

TYP	Ø O	D	X	Y	Z	V	P	T	U	R	SYL Ø
GIHR-K	35	M 28x1,5	70	58	29	40	38	25	30	39	63
MIRO-XL	45	M 36x2	95	74	42	50	45	32	40	53	80
MIRO-XL	60	M 42x3	115	85	47	60	57	44	50	68	100
GIHR-K	60	M 58x1,5	130	90	59	75	65	44	50	65	100
MIRO-XL	70	M 56x3	137	105	57	70	72	49	60	80	125
GIHN-K	70	M 56x2	160	135	76	80	70	70	57	77,5	125
GIHR-K	70	M 65x1,5	150	100	66	86	75	49	55	77	125
MIRO-XL	80	M 64x3	155	112	66	80	80	55	65	90	140
GIHN-K	80	M 64x3	180	148	86	90	78	80	66	84	140
GIHR-K	80	M 80x2	170	125	81	102	80	55	60	88	140
MIRO-XL	90	M 72x3	174	130	72	90	90	60	70	100	160
GIHN-K	90	M 72x3	195	160	91	100	85	90	72	92,5	160
GIHR-K	90	M 100x2	210	146	101	124	90	60	65	103	160
MIRO-XL	100	M 80x4	200	150	85	100	100	70	80	110	180
GIHN-K	100	M 80x3	210	178	96	110	98	100	84	105	180
GIHR-K	100	M 110x2	235	166	111	138	105	70	70	115	180
MIRO-XL	110	M 90x4	230	150	95	120	115	70	80	125	200
GIHN-K	110	M 90x3	235	190	106	125	105	110	88	117,5	200
GIHR-K	110	M 120x3	265	190	125	152	115	70	80	132,5	200
MIRO-XL	140	M 110x4	260	200	110	150	125	90	100	162	250
GIHN-K	160	M 125x4	310	250	126	165	150	160	130	163	320